



# The Professional Photo SourceBook

## Section 5

### Pro Accessories

Pro Lens Hoods . . . . .	246-250, 253
Montagers & Vignettters ..	250-253
Brackets . . . . .	254-261
MF View Camera Converter ...	261
Pouches, Wraps . . . . .	262-264
Lens Caps, Stack Caps . . . . .	265
Lens Hoods . . . . .	266
Stepping Rings . . . . .	267-272
Cleaning Supplies . . . . .	273-275
Focus Cloths, Changing Bags ..	276
Cables . . . . .	277
Film Backs . . . . .	278-281
Misc. Accessories . . . . .	282-283
Focusing Screens . . . . .	284-286
Shutters, Lensboards . . . . .	287
Extenders, Viewers . . . . .	288
Two-Way Radios . . . . .	289
Ladders . . . . .	290

# PRO LENS HOODS

A M B I C O S H A D E +

PRO ACCESSORIES  
246

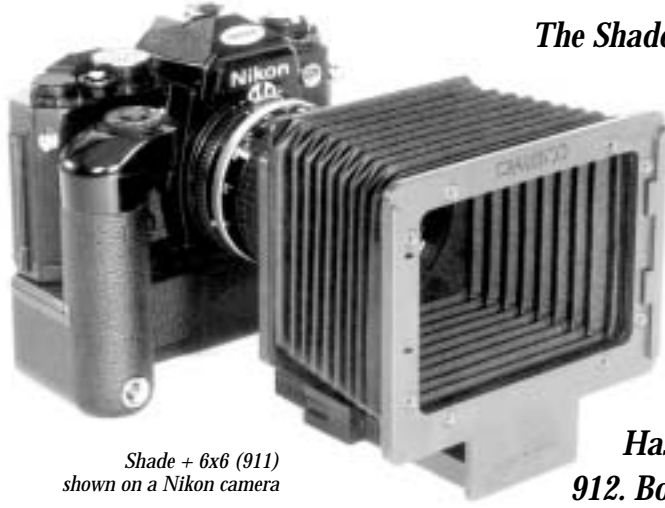

Shade + 6x6 (911)  
shown on a Nikon camera

*The Shade + is an adjustable lens shade for 35mm and 2¼ cameras. Bellows compress while slide track folds for portability while carrying. Made of high impact polycarbonate and anodized aluminum. Rear standard accepts any 3 x 3" material up to 1/16th" thick, front standard accepts 3½ x 4½" (model #911) and 4½ x 4½" (model #912) special masks and vignettes. 35mm cameras and 6x4.5cm Bronica, Mamiya and Pentax cameras accept model #911, while medium format 6x6 and 6x7cm cameras, including Hasselblad, Bronica, Mamiya, Pentax and Rollei accept model 912. Both Shade + are attached to lenses with adapters.*

**Shade + 35mm (911)**  
For 35mm and 6x4.5 cameras.  
Requires adapter ring.  
**Item # AMSP35.....49.95**

**Shade + 6x6 (912)**  
For 6x6 and 6x7 cameras.  
requires adapter ring.  
**Item # AMSP66.....54.95**

### Adapters

**49mm Adapter (949)**  
**Item # AMAR49SP.....12.95**

**Series 8 Adapter (908)**  
**Item # AMARS8SP.....19.95**

**52mm Adapter (952)**  
**Item # AMAR52SP.....12.95**

**Hasselblad Adapter Bay 50 (909)**  
**Item # AMARB50SP.....32.95**

**55mm Adapter (955)**  
**Item # AMAR55SP.....12.95**

**Hasselblad Adapter Bay 60 (910)**  
**Item # AMARB60SP.....48.50**

**58mm Adapter (958)**  
**Item # AMAR58SP.....12.95**

**75mm to 67mm Adapter (931)**  
Allows use of Cokin A Series (67x67mm) filters to be used in rear standard accepting 3x3" (75x75mm) material.  
**Item # AMFA7567SP.....19.50**

**62mm Adapter (962)**  
**Item # AMAR62SP.....12.95**

**67mm Adapter (967)**  
**Item # AMAR67SP.....12.95**

**72mm Adapter (972)**  
**Item # AMAR72SP.....12.95**

**77mm Adapter (977)**  
**Item # AMAR77SP.....12.95**

### Filter Set

Can be combined or used individually. Consists of rainbow, soft-focus and starburst filters.

**3x3 Filter Set (925)**  
Fits into rear standard.  
**Item # AMFSCSP.....18.95**

### Vignettes

Use special masks to create appealing vignettes of your subject. Each set consists of 8 vignettes of different openings. 4 brown plastic and 4 slightly fogged plastic.

**35mm Vignette Set (921)**  
3½ x 4½". Fits shade + 35mm.  
**Item # AMVSSP35.....18.95**

**2¼ Vignette Set (922)**  
4½ x 4½". Fits shade + 6x6.  
**Item # AMVSSP66.....18.95**

### Montage

For special effects with multiple exposures. Consists of 8 cutout masks, including center circle, star, cross, heart, corner cutouts, ovals, split field and one blank to design yourself.



**35mm Montage Set (923)**  
3½x4½". Fits shade + 35mm.  
**Item # AMMSSP35.....18.95**

**2¼ Montage Set (924)**  
4½x4½". Fits shade + 6x6.  
**Item # AMMSSP66.....18.95**

### Multiple Exposure

Use for simplicity in getting multiple exposure photos.

**35mm Multiple Exposure Set (928)**  
3½x4½". Fits shade + 35mm.  
**Item # AMMESSP35.....18.95**

**2¼ Multiple Exposure Set (929)**  
4½x4½". Fits shade + 6x6.  
**Item # AMMESSP66.....18.95**

### Holographic Filter Set

Rainbow-like filter for appealing highlights and special effects.

**Holographic Filter Set (930)**  
Fits into rear standard.  
**Item # AMFSHSP.....23.95**

### Filters

Light goes through plastic sheets to transfer color. Square holder.

**Acetate Filter and Holder (932)**  
Fits into rear standard.  
**Item # AMAHKSP.....23.95**

**Blank Masks, 35mm (933)**  
3½x4½". Fits shade + 35mm.  
**Item # AMMBSP35.....26.95**

**Blank Mask, 2¼ (934)**  
4½ x 4½". Fits shade + 6x6.  
**Item # AMMBSP66.....26.95**

# PRO LENS HOODS

## L I N D A H L B E L L - O - S H A D E

*The Bell-O-Shade is an adjustable pro lens hood that reduces flare and increases color saturation. It fits a number of cameras and most lenses from 35-105mm on 35mm format, 50-150mm on 6x6/6x7 format and 90-180mm on 6x7 format. The hood is constructed of a quality bellows and durable injection-molded ABS plastic. The Bell-O-Shade can be extended 2" to 6", allowing it to be used with a variety of different focal length lenses. Next to the lens is a 1/4" x 3" square slot to accommodate filters. The front standard accepts 4 1/2" square mounting masks or vignettes.*

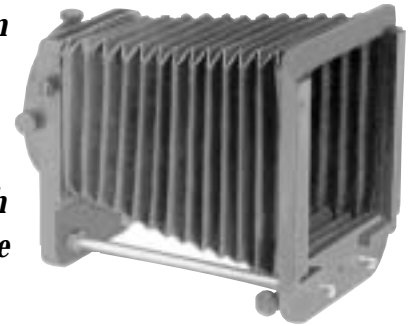

**Bell-O-Shade Standard** (311320)  
With 4" extension rods.  
Requires size 8 adapter ring.  
**Item # LIBOS.....125.10**

**Bell-O-Shade Hasselblad CF** (311325)  
With 4" extension rods. Fits directly onto Hasselblad CF lenses using 60mm bayonet mount.  
**Item # LIBOSH.....140.40**

**Double Filter Slot Bell-O-Shade Standard** (311530)  
For portrait lenses. Same as Bell-O-Shade Standard, with two 3" square filter slots next to lens for diffusers and glass, gelatin, and small Cokin filters, and any self-made filters. Requires size 8 adapter ring.  
**Item # LIBOSDFS.....140.40**

**Double Filter Slot Bell-O-Shade Hasselblad CF** (311535)  
Same as Bell-O-Shade Standard, with two 3" square slots next to lens. Fits directly onto any Hasselblad portrait lens using a 60mm bayonet mount.  
**Item # LIBOSDFSH.....157.50**

### Replacement Rods

Replaces broken, bent or lost rods. Sold in packages of 2 only.

**4" Rods Pkg of 2** (441124)  
**Item # LIR4.....9.95**

## PROFESSIONAL VIGNETTER (DOUBLE BELLOWS)

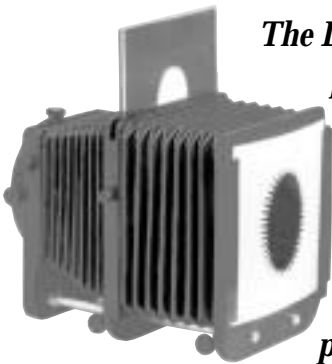

*The Double Bellows is used as a lens shade (which extends from 4" to 10"), and as a professional vignetter. The vignetting system has three standards for vignettes or filters. Next to the lens is a single (#43-1230, #43-1235) or double (#43-1240, #43-1245) 3" square slot for filters or diffusers. The center standard is for 4 1/2" glass "neutral-density" vignettes. Any vignetting device that may cause flare should be used here. The front standard is for 4 1/2" Hi-Key vignetting and double exposures. The front of the vignetter has metal plates which allow the use of convenient magnetic vignettes.*

**Double Bellows Standard** (431230)  
Adjustable bellows. With 2" and 4" rods. Requires size 8 adapter ring.  
**Item # LIVU.....241.20**

**Double Bellows Hasselblad CF** (431235)  
With 2" and 4" rods. Fits directly onto Hasselblad CF lenses using 60mm bayonet mount.  
**Item # LIVUH.....250.20**

**Double Bellows Standard with Double Filter Slot** (431240)  
With 2" and 4" rods. Same as Double Bellows Standard with two 3" square filter slots next to lens. Requires size 8 adapter ring.  
**Item # LIVUDFS.....261.10**

**Double Bellows Hasselblad with Double Filter Slot** (431245)  
With 2" and 4" rods. Same as Double Bellows Hasselblad, with two 3" square filter slots next to lens. Fits directly onto Hasselblad CF lenses using 60mm bayonet mount.  
**Item # LIVUDFSH.....277.20**

**Hasselblad CF lenses using 60mm bayonet.**  
**Item # LIVUDFSH.....277.20**

**Complete Vignetting System Standard** (431220)  
Same as Double Bellows Standard (#43-1230). Also includes four 4 1/2" Hi-Key vignettes (#43-1206) and four

**Complete Vignetting System Hasselblad** (431225)  
Same as Double Bellows Hasselblad (#43-1235). Also includes four 4 1/2" Hi-Key vignettes (#43-1206) and four 4 1/2" glass vignettes (#43-1205). Requires size 8 adapter ring.  
**Item # LIVSKH.....312.30**

### Replacement Rods

4 1/2" glass vignettes (#43-1205). Requires size 8 adapter ring.  
**Item # LIVSKS.....296.10**



# PRO LENS HOODS

## LINDAHL COMPENDIUM II



Compendium II (441000)

*Compendium II fits 120 and 35mm cameras, and offers improved features and a larger size to accommodate wide-angle lenses. All Compendium II's feature a single bellows designed to hold 4" filters next to the lens and a 5½" square front to allow use of wide angle lenses, and to hold vignettes or special effect devices.*

**Compendium II Lens Shade (441000)**

With a rear filter slot to hold a 4" filter, and a front filter slot to hold a 5½" filter, rack and adjustment knob, two 6" rods and rod holder plate. Requires size 9 adapter ring and base mounting hardware, each sold separately.

**Item # LIC2 .....199.95**

**Compendium II Wide Angle System (449910)**

For use with wide angle lenses up to 90° diagonal. Requires size 9 adapter ring.

**Item # LIC2KWA .....219.95**

**Compendium II Telephoto System (449912)**

For use with long telephoto and/or zoom lenses. Requires size 9 adapter ring.

**Item # LIC2KTQ .....219.95**

**Compendium II Portrait System (449911)**

For use with portrait lenses. Requires size 9 adapter ring.

**Item # LIC2KP .....219.95**

**Compendium II Fuji GX 680 System (449917)**

For use with Fuji GX 680 with 100-300mm lenses. Includes 82mm size 9 adapter ring.

**Item # LIC2KFGX .....243.95**

**Compendium II for Mamiya RZ-67 with 100-200 Zoom Lens and Auto Winder (449914)**

Features a free-floating adapter ring mounting system. As the lens is zoomed or focused, the lens shade remains stationary. Since the weight is under the camera, it provides easy zooming and focusing. Includes 77mm size 9 adapter ring.

**Item # LIC2KMRZZW .....278.95**

## LINDAHL COMPENDIUM II ACCESSORIES

**Auxiliary Bellows (442000)**

Fits Compendium II. Adds auxiliary bellows and shades vignettes from flare. Attaches magnetically and can be removed for wide-angle work.

**Item # LIBAC2 .....93.50**

**4½" to 5½" Vignette Converter (445110)**

Allows use of 4½" vignettes in the Compendium II. Works with glass neutral-density vignettes.

**Item # LIC4.55.5 .....14.95**

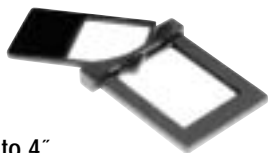

**3" to 4" Filter Slot Converter (444110)**

Allows the use of 3" filters in the Compendium II.

**Item # LIC34 .....11.95**

**Additional Filter Slot**

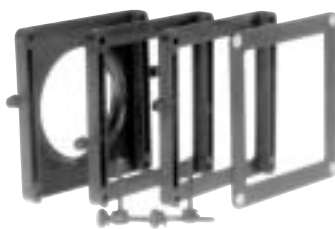

Additional filter slots may be purchased to add on to the Compendium II Shade. You can add a second filter slot to use multiple filters at the same time. You can select a top or side filter slot opening when attaching this filter slot.

**Second Filter Slot with Screws (441102)**

**Item # LIFS2C2 .....15.95**

**Base Mounting Hardware**

The Base Mounting Hardware is the link between your camera and your lens shade. It attaches to the camera and then to the rails of the Compendium II. Available in different lengths and styles to custom fit your camera and lens combinations.

**Short Mounting Hardware (441050)**

Used with wide angle and normal focal length lenses.

**Item # LIMHSQ .....47.50**

**Medium Mounting Hardware (441051)**

Used with portrait length lenses.

**Item # LIMHM .....47.50**

**Long Mounting Hardware (441052)**

Used with telephoto lenses.

**Item # LIMHL .....47.50**

**Fuji GX-680 Mounting Hardware (441070)**

**Item # LIMHFGX .....46.95**



Assorted Base Mounting Hardware

**Mounting Hardware for Mamiya RZ-67 with 100-200 Zoom Lens with Auto Winder (441053)**

**Item # LIMHMRZZ .....71.95**

# PRO LENS HOODS

## LINDAHL COMPENDIUM II LARGE FORMAT LENS SHADE

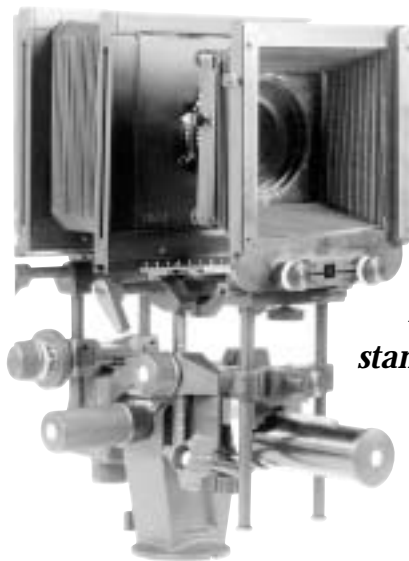

*An adjustable lens shade for large format view cameras that offers flexible positioning to eliminate unwanted light, and thus, unwanted lens flare. All Compendium II's feature a single bellows designed to hold 4" filters next to the lens, and a 5 1/2" square front to hold vignettes and/or special effect devices. Unlike other shades, the weight of the Compendium II is supported by uniquely designed mounting hardware that attaches to the rail of your camera. This "mini view camera standard" puts no stress on the lens filter threads or on the front standard. The adjustments on the mounting hardware allow your shade to rise and fall and shift with the lens as needed.*

Compendium II System for Sinar, Calumet, Plaubel and Toyo (449909)  
 With mounting hardware and 4" gel holder. Requires size 9 adapter ring.  
 Item # LIC2KS .....264.50

PRO ACCESSORIES  
249

## LINDAHL ADAPTER RINGS

### Size 8 Adapter Rings

Gives secure mounting and protection to lenses. These plastic rings are lightweight, and, if cross-threaded, will not damage the threads on lens. Size 8 rings are used with the Bell-O-Shade, Professional Vignetting System (double bellows), fixed montagers and hi-key vignetter.

49mm Threaded Adapter (111049) Item # LIAR49 .....14.40	58mm Threaded Adapter (111058) Item # LIAR58 .....14.40	72mm Threaded Adapter (111072) Item # LIAR72 .....19.95
52mm Threaded Adapter (111052) Item # LIAR52 .....14.40	62mm Threaded Adapter (111062) Item # LIAR62 .....14.40	77mm Threaded Adapter (111077) Item # LIAR77 .....19.95
55mm Threaded Adapter (111055) Item # LIAR55 .....14.40	67mm Threaded Adapter (111067) Item # LIAR67 .....14.40	Hasselblad C 50mm Adapter* (111001) Item # LIARHC.....21.95

\*Please note: Hasselblad CF (60mm) lenses require the CF version of the Bell-O-Shade products. CF versions can be used on non-CF Hasselblad lenses, as well as other cameras, with the proper adapter listed above.

### Size 9 Adapter Rings

Size 9 adapter rings are used with the Compendium II lens shade systems and Compendium II large format lens shade.

49mm Threaded Adapter (119049) Item # LIAR49C2.....27.95	62mm Threaded Adapter (119062) Item # LIAR62C2.....27.95	82mm Threaded Adapter (119082) Item # LIAR82C2.....27.95
52mm Threaded Adapter (119052) Item # LIAR52C2.....27.95	67mm Threaded Adapter (119067) Item # LIAR67C2.....27.95	Hasselblad B-50 C Adapter (119001) Item # LIARHCC2.....36.50
55mm Threaded Adapter (119055) Item # LIAR55C2.....27.95	72mm Threaded Adapter (119072) Item # LIAR72C2.....27.95	Hasselblad B-60 CF Adapter (119005) Item # LIARHCFC2.....39.95
58mm Threaded Adapter (119058) Item # LIAR58C2.....27.95	77mm Threaded Adapter (119077) Item # LIAR77C2.....27.95	Rollei Bay 6 Adapter (119006) Item # LIARRC2.....36.50
Special Order! Custom Adapter (119009) Item # LIARCC2.....37.95		



THE PROFESSIONAL'S SOURCE (212) 444-6630 • FAX: (212) 239-7770

1 • 8 0 0 • 9 4 7 • 6 6 5 0

# MONTAGERS/ADAPTERS

## LINDAHL MONTAGERS

PRO ACCESSORIES  
250

### SLR Montager

A fixed montager for SLR cameras positions 4½" multiple exposure masks into front of montager for special effects, when used with the normal lens. Adjustments cannot be made.

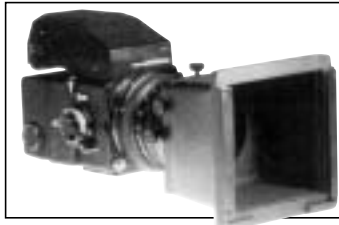

**SLR Montager Standard** (311420)  
With eight 4½" basic montaging masks for multiple exposure (#31-1301). Requires size 8 adapter ring.  
**Item # LIMSLRS** .....**94.95**

**SLR Montager Hasselblad CF** (311425)  
With eight 4½" basic montaging masks for multiple exposure (#31-1301). Fits directly onto all Hasselblad CF lenses using a Bay 60 mount.  
**Item # LIMSLRH**.....**109.95**

### TLR Montager

A fixed montager for TLR cameras. Positions 4½" multiple exposure masks in front of montager for special effects when used with the normal lens. Adjustments cannot be made.

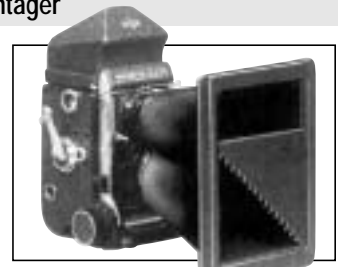

**TLR Montager for Mamiya C** (311330)  
With eight 4½" basic montaging masks for multiple exposure (#31-1301). Fits directly onto standard lens.  
**Item # LIMTLRMC** .....**94.95**

**TLR Montager for Rolleiflex** (311340)  
With eight 4½" basic montaging masks for multiple exposure (#31-1301). Specify Rollei bay size.  
**Item # LIMTLRR**.....**94.95**

## LINDAHL ULTRA EFX SHADE

*The Ultra EFX Shade is designed to function in harmony with today's 35mm SLR cameras and lenses. It is precision-engineered to work on both autofocus and rotating zoom lenses through a revolutionary adapter system. The shade remains stationary and in-line with the camera at all times. The Ultra EFX Shade features a quick and easy-to-use 35mm lens shade with the ultimate in lens and filter protection. Professional looking effects with lightweight construction. Works on lenses 28mm and longer. It accepts Cokin A and P, 3" Lindahl EFX filters and front 4.5 x 3.5" (114 x 90mm) vignette slot.*

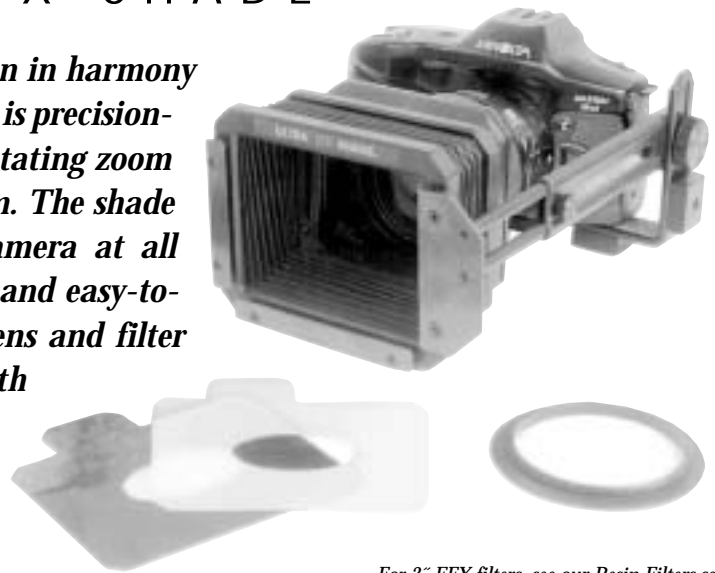

For 3" EFX filters, see our Resin Filters section.

**Ultra EFX Shade** (351620)  
With a mounting bracket, one diffusion filter, two vignettes. (Requires adapter disk.)  
**Item # LILHUEFX** .....**99.00**

**Motor Drive Bracket** (351701)  
For motor drive cameras.  
**Item # LIBMD**.....**19.95**

**2" Extension Rods** (351902)  
Set of 2.  
**Item # LIERUEFX**.....**9.95**

### EFX Adapter Disks

**49mm Threaded Adapter Disk** (113049)  
**Item # LIAD49**.....**14.95**

**52mm Threaded Adapter Disk** (113052)  
**Item # LIAD52**.....**14.95**

**55mm Threaded Adapter Disk** (113055)  
**Item # LIAD55**.....**14.95**

**58mm Threaded Adapter Disk** (113058)  
**Item # LIAD58**.....**14.95**

**62mm Threaded Adapter Disk** (113062)  
**Item # LIAD62**.....**14.95**

**67mm Threaded Adapter Disk** (113067)  
**Item # LIAD67**.....**14.95**

**72mm Threaded Adapter Disk** (113072)  
**Item # LIAD72**.....**14.95**

**77mm Threaded Adapter Disk** (113077)  
**Item # LIAD77**.....**14.95**

**82mm Threaded Adapter Disk** (113082)  
**Item # LIAD82**.....**14.95**

We are on the web at: <http://www.bhphotovideo.com>

# MONTAGERS/VIGNETTERS

## LINDAHL HI-KEY VIGNETTER

*Hi-Key Vignetter uses a "no bellows" principle to allow light to fall on both sides of the vignette to achieve a correct hi-key vignette. By installing the small probe and bracket, you can have perfect hi-key vignetting any time, any place. Included with the system are 4 white magnetic vignettes. These vignettes attach to the front frame and allow you to place your vignettes precisely where you want them. To control the degree of vignetting, the front standard is adjustable and can be locked down with the thumb screw. Next to the lens is a 3" square slot for filters and diffusers.*



### Hi-Key Vignetter System Standard (431260)

Includes one hi-key vignetter unit, four hi-key magnetic vignettes, one mini strobe, one bracket for mini strobe. Requires size 8 adapter ring.

Item # LIHKVS.....98.10

### Hi-Key Vignetter System Hasselblad (431265)

Includes one hi-key vignetter unit, four hi-key magnetic vignettes, one mini strobe, one bracket for mini strobe. Fits directly onto Hasselblad CF lenses, using Bay 60 size.

Item # LIHKVH.....115.20

PRO ACCESSORIES

251

## LINDAHL MONTAGING MASKS (DOUBLE EXPOSURE)

### Pro Montaging Masks (311303)

Contains 10 masks for multiple exposure. The masks are 4 1/2" square and fit Lindahl vignetting systems, Bell-O-Shade, fixed montagers and 4 1/2" slots of other manufacturers.

Item # LIMMPS.....33.50

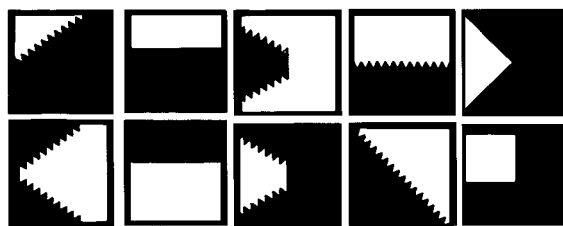

Pro Montaging Masks (311303)

### Reflections Double Exposure Plate (311305)

4 1/2" plate designed to be used in the center standard of the Vignetting System. By making your first exposure with the bottom portion in place, then rotating it, you can achieve high quality double exposures.

Item # LIRDEP .....24.95



## LINDAHL GLASS NEUTRAL-DENSITY VIGNETTES

*These vignettes do not change the color of the subject in the background, they simply darken the corners of your photograph. They are useable on a large pattern of apertures. These 4 1/2" square vignettes achieve their effect through carefully selected extremely durable patterns printed on the surface. They can be customized for a particular photographer's style. Requires the Professional Vignetter.*

### #A Oval Neutral-Density Vignette (431291)

Item # LIVNDOG.....25.95

### #C Bottom Arc Neutral-Density Vignette (431293)

Item # LIVNDBSG .....25.95

### #B Circle Neutral-Density Vignette (431292)

Item # LIVNDCG .....25.95

### #D Bottom Straight Neutral-Density Vignette (431294)

Item # LIVNDBSGQ .....25.95

### Complete Set of 4 Neutral-Density Vignettes (431295)

This complete set of vignettes consists of a #A Oval-Neutral, #B Circle, #C Bottom Arc, and #D Bottom Straight neutral-density vignettes.

Item # LIVSNADAD .....69.95



THE PROFESSIONAL'S SOURCE (212) 444-6630 • FAX: (212) 239-7770

1 • 8 0 0 • 9 4 7 • 6 6 5 0

# VIGNETTES

## LINDAHL VIGNETTES

PRO ACCESSORIES  
252

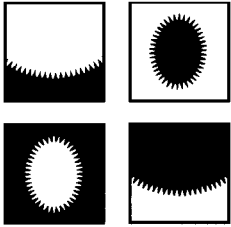

Basic Vignette Pack  
(431208)

**Basic Vignette Pack (431208)**  
This basic package contains four vignettes designed for larger apertures. These simple vignettes are ideal for use in the Bell-O-Shade and perfect for the beginner as well as the experienced professional. Set includes 2 black and 2 white 4 1/2" square slip-in vignettes.  
**Item # LIVSB.....25.95**

**Basic Vignette Pack Magnetic (431211)**  
For larger apertures. These 4 magnetic vignettes allow maximum flexibility in the placement of your vignettes. Recommended for the Bell-O-Shade or Professional Vignetter. Set includes 2 black and 2 white magnetic vignettes.  
**Item # LIVSMB.....28.50**

**Mid-Key Vignettes (433010)**  
Designed to produce the popular mid-key look. By creating an effect that is neither dirty brown or stark white, this vignette blends beautifully with Hi and Mid-Key setting. If a pure white effect is desired, simply illuminate the vignette as you would any Hi-Key vignette.  
**Item # LIVSMK.....44.95**

### Low-Key Vignette Kit

#### Low-Key Custom Vignette Kit (431251)

A 6-piece kit containing 6 uncut mesh screens mounted to a plastic 4 1/2" square frame.

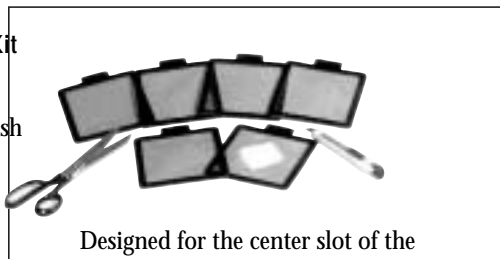

Designed for the center slot of the

Vignetting System. Also usable on a wide range of pro lens hoods, accepting 4 1/2" accessory size. Enables you to make your own vignettes, just as many recognized photographers do.

**Item # LIVSL6K.....37.95**

### Cricchio Soft Edge Vignettes

#### Soft Edge Vignettes (431270)

Designed by the world renowned photographer Frank Cricchio for use in Hi-Key photographs. These 4 1/2" soft edge vignettes gently diffuse the edge of portraits giving you a beautiful effect.

Coming as a set of 6, the Soft Edge Vignettes includes small and large vertical oval, small and large horizontal oval, and small and large diagonal oval design. Usable on a wide range of pro lens hoods accepting 4 1/2" accessory size.

**Item # LIVSC6.....87.50**

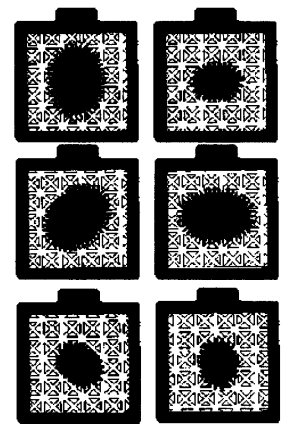

### Clearflex Vignettes

4 1/2" Clearflex Vignettes are neutral smoke gray color vignettes for normal focal length lenses. They are usable over a wide range of apertures and are made of rubber styrene. These vignettes will alleviate problems with other types of low-key vignettes by having them pre cut for every situation. Sold in a set of 10, which includes small and large vertical oval, small and large horizontal oval, and high and low bottom arch.

**1.0 Smoke Gray Clearflex Vignettes (432030)**  
Set of 10.  
**Item # LIVCF1.....53.95**

**1.5 Smoke Gray Clearflex Vignettes (432040)**  
Set of 10.  
**Item # LIVCF1.5.....53.95**

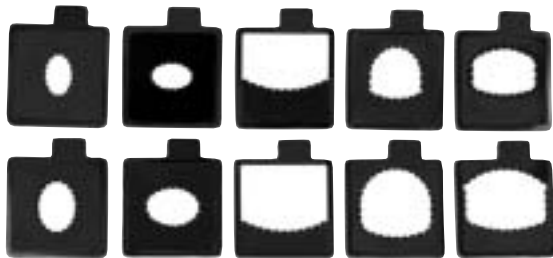

4 1/2" Smoke Gray Clearflex Vignettes

### Creativity (Vignette) Kits



4 1/2" graduated vignettes made of a molded plastic mesh material. Each set works at apertures of f/8 and larger. Contains 6 Vignettes - small and large horizontal oval, small and large vertical oval, small and large bottom arch design. They can be snapped together in pairs, or used individually to form custom Vignettes. Usable on a wide range of pro lens hoods accepting 4 1/2" accessory size.

**Creativity Kit, Clear (431288)**  
Set of 6. For hi-key vignetting. A large aperture alternative to glass.  
**Item # LICKC .....47.50**

### Converter

**4 1/2" to 5 1/2" Converter (445110)**  
Convert 4 1/2" vignetting masks to be used on Compendium II lens hoods, or other brand hoods using 5 1/2" accessory slot.  
**Item # LIC4.55.5.....14.95**

### Wood Storage Boxes

**Wood Box for 4 1/2" Devices (231120)**  
With partitions. Holds 8 vignettes. Ideal for storage of glass vignettes.  
**Item # LISBWW4.5 .....39.95**



# PRO LENS HOODS

## SAILWIND

*The Sailwind Pro Vignetta Matte System has a unique design which greatly reduces flare. Its metal construction assures a very durable Pro Lens Hood. The rack and pinion focusing rail moves smoothly in and out for perfect positioning. It accepts up to two glass, plastic or double thick professional filters in the rear and will accommodate slip-in or magnetized vignettes or montagers on the bellows front. An accessory bellows is available to extend the Pro Bellows for utilizing the low-key vignettes or other accessories.*



Pro Vignetta Matte Bellows shown with Auxiliary Bellows

*Lens adapter rings are available to fit 49mm-82mm Hasselblad Bayonet 50, 60 and Rollei Bay 6.*

Pro Vignetta Matte Bellows  
Item # SAPB.....**229.88**

Auxiliary Bellows  
Item # SAPAB.....**99.88**

### Lens Adapter Rings

49mm Lens Adapter Ring (49AR) Item # SAAR49..... <b>19.95</b>	77mm Lens Adapter Ring (77AR) Item # SAAR77..... <b>21.95</b>
52mm Lens Adapter Ring (52AR) Item # SAAR52..... <b>19.95</b>	82mm Lens Adapter Ring (82AR) Item # SAAR82..... <b>29.95</b>
55mm Lens Adapter Ring (55AR) Item # SAAR55..... <b>19.95</b>	Bay 50 Lens Adapter Ring (B50AR) For Hasselblad C lenses. Item # SAARB50..... <b>24.95</b>
58mm Lens Adapter Ring (58AR) Item # SAAR58..... <b>19.95</b>	Bay 60 Lens Adapter Ring (B60AR) For Hasselblad CF lenses. Item # SAARB60..... <b>29.95</b>
62mm Lens Adapter Ring (62AR) Item # SAAR62..... <b>19.95</b>	72 Bay Lens Adapter Ring (72BAR) For Rollei lenses with Bay 6. Item # SAARB72..... <b>29.95</b>
67mm Lens Adapter Ring (67AR) Item # SAAR67..... <b>19.95</b>	Camera Mounting Ring Replacement. Item # SAMRB..... <b>19.95</b>
72mm Lens Adapter Ring (72AR) Item # SAAR72..... <b>21.95</b>	

### Vignetter and Montager Kits

<b>Sailwind/Leon Portrait Scoop Vignetter Kit (LPS)</b> Three black mesh magnetized scoop vignettes, in three densities: light, medium and dark for blending the lower portion of the image area. Item # SALPVK..... <b>59.95</b>	<b>Sailwind Soft Frost Vignetter Kit (SF)</b> Eight oversized magnetized vignettes allow the photographer to put the vignetting effect anywhere in the image area. Four clear-soft vignettes for light blending of backgrounds and four frosted vignettes for high key effect. The kit includes one large and one small oval vignetter, and one large and one small circular vignetter. Item # SASFVK..... <b>69.95</b>
<b>Sailwind/Leon Vignetter Kit (LVK)</b> Eight plastic slip-in vignettes with four different circular openings. Four translucent vignettes are for high-key vignetting, and four brown vignettes are for low-key. Item # SALVK..... <b>39.95</b>	<b>Sailwind/Leon High Key Vignetter Kit (LHK)</b> Seven magnetized translucent high key vignettes in scoops, half-vignettes, S-curve and two oversized in bell and triangle patterns - great for bridal portraits. Produces beautiful high key images for head and shoulders or full length portraits in the studio or outdoors. Item # SALHKVK..... <b>59.95</b>
<b>Sailwind/Leon Pro II Vignetter Kit (LPII)</b> Three magnetized black mesh vignettes with oval openings for gently blended, low-key vignetting in the studio or outdoors. Item # SALP2VK..... <b>59.95</b>	<b>Sailwind Montager Kit</b> 15 masks of different shapes make it easy to do mantaging and to create double and multiple exposures. Great for weddings, school portraits, and creating unique images. Item # SAMMK..... <b>79.88</b>
<b>Sailwind/Leon Hi Net Vignetter Kit (LHN)</b> Three white net magnetized vignettes with oval openings for a lighter medium key blending of the image edges. Looks great with lighter color backgrounds Item # SALHNVK..... <b>59.95</b>	

### Adapter Plates

**Vignetter Adapter Plate**  
Allows non-magnetized bellows to accept magnetized accessories.  
Item # SAAPB.....**21.95**

**Vignetter Adapter Plate**  
For Mamiya G-3 Bellows.  
Item # SAAPMG3.....**24.95**

**Vignetter Adapter Plate**  
For Hasselblad Pro Shade 6093.  
Item # SAAPHPS.....**34.95**

### Bellows Accessories

**3x3" Metal Filter Holders**  
For Sailwind Bellows.  
Item # SAFHM33.....**19.95**

**3x3" Filter Holder**  
for Cromatek Filters  
Item # SAFHC33.....**21.95**

**3x3" Plastic Filter Holders**  
Two peel-apart and press-apply holders mount any 3x3" filter.  
Item # SAFHP33.....**5.95**



# BRACKETS

## C R A N E

### Multi-Brackets

A must for all wedding photographers or anyone who does location/candid and multiple-light shooting, the Multi-Bracket is designed to conveniently hold your portable flash, power supply, radio slave receiver or photo slave and an umbrella for bounce lighting with the strobe sensor facing subject, allowing automatic exposure control (except MB-2). They are excellent when mounted on a mono-pod or small light stand for easy mobility or for use on an extension pole and are extremely well balanced. Equipped with a flash "quick release" for your convenience and an adjustable tilting head for easy positioning, they accept all stands up through 5/8". Multi-Brackets are offered in four different models to accommodate virtually all portable strobes.

**Multi-Bracket MB-1**  
Fits Sunpak Auto-Pro 120J, Lumedyne, Norman, Quantum Q-Flash, and Mini Lights AC/DC Version (1/4"-20 thread mount).  
**Item # CRMB1.....69.95**

**Multi-Bracket MB-2**  
Fits Vivitar 283/285 and all "shoe-mount" style flash heads.  
**Item # CRMB2.....69.95**

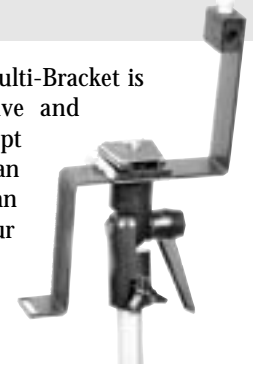
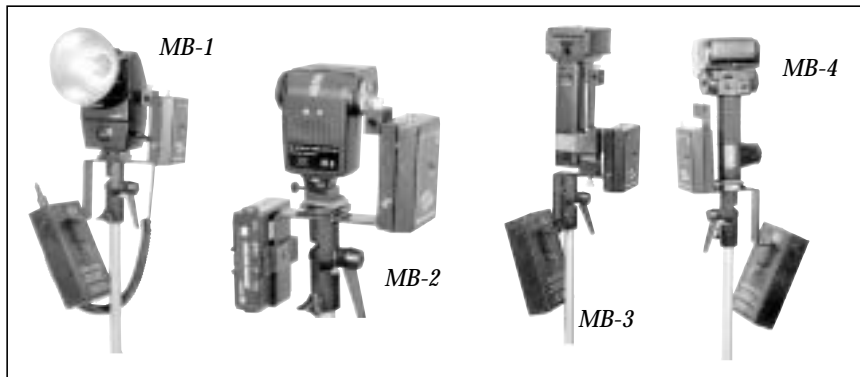

**Multi-Bracket MB-3**  
Fits all Metz 45/60 Series strobes (w/Metz quick-release).  
**Item # CRMB3.....69.95**

**Multi-Bracket MB-4**  
Fits all Sunpak "handle-mount" flashes.  
**Item # CRMB4.....69.95**

### Universal (U.B.H.) Battery Holder

The Universal Battery Holder is specifically designed to securely hold all Quantum, Lumedyne and Metz 60 Series battery packs to most light stands, mono-pods and tripods. Its rigid, extremely lightweight aluminum construction provides great benefit without adding excess weight to your bag. Ideal for commercial,

wedding, location or studio use. Recommended for use with Lumedyne systems and Metz 60 Series strobes when using Multi-Brackets MB-1, MB-2, MB-3, and MB-4. Black Anodized.

**Universal Battery Holder**  
**Item # CRBHU.....34.95**

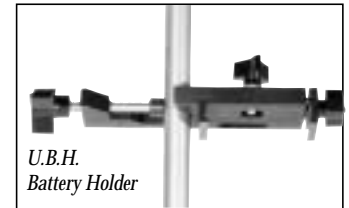

U.B.H. Battery Holder with Metz battery pack

### Small Battery Holder (S.B.H.)

The small battery holder was designed to securely hold all Quantum battery packs and other items with a belt clip (i.e. belt pouch for film magazines, Filter and Vignette Pouch) to most light stands, mono-pods and tripods. Its small, lightweight design is ideal for wedding, location and studio use. Black Anodized.

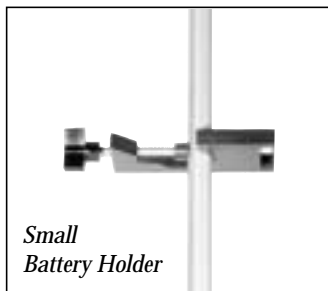

Small Battery Holder



Small Battery Holder with Quantum Battery Pack

**Small Battery Holder**  
**Item # CRBHS.....21.95**

### 35mm Quick Shoe (35QS) "The Best"

The 35mm Quick Shoe provides quick camera mounting, while eliminating thread wear on the camera. The small light-weight foot can remain on the camera for quick mounting. Additional camera feet are available.

**Item # CRQS .....54.95**

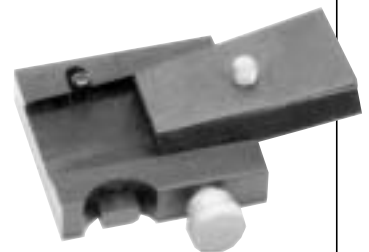

**All items are complete with all accessories as supplied by the manufacturer**

# BRACKETS

## NEWTON 7000 SYSTEM

The Newton 7000 Bracket System is small and lightweight. Milled from 6061T aluminum, these brackets offer the professional photographer a compact and strong support for camera and flash systems. The Newton 7000 System keeps your flash directly over the camera lens for shadow and "red eye" control. All Series 7000 brackets have the EZR camera release. The EZR System is a safe and easy way of removing the camera from any of the 7000 series brackets.

### Universal Camera Rotator Bracket (N7000)

With flash cable release and allen keys. Allows positive and secure movement from horizontal to vertical positions, keeping the flash directly over the lens for better "red eye" control. Has a built-in 3" height adjustment and can be used with medium format and motorized 35mm SLR's. Weighs only 15.3 oz. Dimensions are 5 x 7 x 4" (HWD).

Item # NEN7000.....114.95



Universal Camera Rotator Bracket (N7000)

### Overhead

Height Extender (N7030)  
For N7100, N7300 and N7400 brackets. Adds 4 1/4".

Item # NEN7030.....19.95

### Forward Extender (N7031)

For same brackets as above. Relocates flash bar forward. Permits use of waist level finders.

Item # NEN7031.....18.50

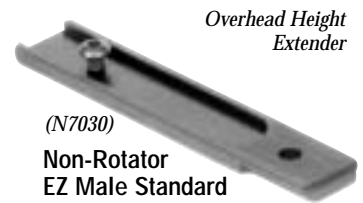

Overhead Height Extender

(N7030)

### Non-Rotator EZ Male Standard (N7040)

Replacement for N7100, or converts N7000 to N7100.

Item # NEN7040.....29.95



Hasselblad Bracket (N7300)

### Hasselblad Bracket (N7300)

Requires Hasselblad grip. Includes flash shoe and allen key. The Hasselblad bracket is designed to attach to the bottom of the Hasselblad flash gun #45072, #46330, #45071, #46329. It gives a strong over-lens support for all flash units including the Hasselblad flash attaches to the camera body. It also allows the Hasselblad flash gun to sit on a solid base and attach to a tripod. Weighs 9 oz. 6x5x2 1/2" (H.W.D.)

Item # NEN7300.....84.00

### Universal Non-Rotator Bracket (N7100)

With flash shoe, cable release and allen keys. Designed for square format cameras, it does not have the camera rotator. Weighs 12 1/2 oz. 5x7x4" (H.W.D.)

Item # NEN7100.....90.00



Universal Non-Rotator Bracket (N7100)

### Bronica SQ Bracket (N7400)

With flash shoe and allen key. The Bronica SQ bracket is designed for the SQA, SQAM or SQAi Bronica cameras with speed grip or motor. Small and compact, it keeps the flash directly over the lens. The overhead unit is easily adjustable for flash height. Weighs 6oz. 5x4x5" (H.W.D.)

Item # NEN7400.....84.00

### 2" Height Extender and Tilt (N7033)

Same as above, but adds two inches.

Item # NEN7033.....23.50

### 4" Height Extender and Tilt (N7034)

Same as above, but adds four inches.

Item # NEN7034.....27.50

### Metz Adapter Platform (N7035)

For use with 45/60 CT, CL flashes.

Item # NEN7035.....29.95



Metz Adapter Platform (N7035)

### Nikon Dedicated Cord/Universal Handle Mount Adapter (N7036)

Item # NEN7036.....16.95

### Canon Dedicated Cord Holder (N7037)

Item # NEN7037.....16.95

### Leather Handstrap (N7038)

For N7000, N7100 brackets.

Item # NEN7038.....26.50

### Replacement Shoe (N7039)

Fits all brackets and adapters.

Item # NEN7039.....16.95

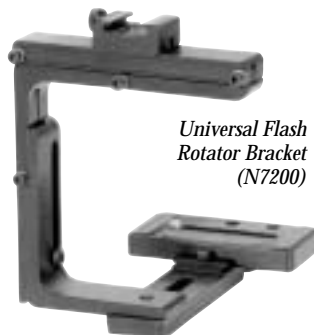

Universal Flash Rotator Bracket (N7200)

### Universal Flash Rotator Bracket (N7200)

With flash shoe and allen keys. Designed for 35mm with or without motor, and medium format with grip that requires rotation. May be used in either the right hand or left hand position. The overhead unit can be adjusted up or down, or in or out to match almost any camera requirement. Weighs 9 oz. 5x4x5" (H.W.D.)

Item # NEN7200.....90.00

### Tripod EZ Male (N7050)

Attaches to tripod, allows camera with EZ female to slide on and lock.

Item # NEN7050.....29.95

### EZ Male Standard for Camera Rotator N700 (N7051) Replacement.

Item # NEN7051.....29.95

EZR Male for Bronica Grip (N705)



Attaches to N7000. Also for some 35's with motors.

Item # NEN7052.....29.95

### EZ Male T90 (N7053)

Allows Canon T90 and some other 35's with motors to attach to N7000.

Item # NEN7053.....44.95

### EZ Male Assembly N7200 Base Only (N7061)

Converts older Newton Flash Rotators to EZ style.

Item # NEN7061.....64.95

EZ Male Assembly N7200 Base Only (N7061)



# BRACKETS

## NEWTON 7000 SYSTEM

PRO ACCESSORIES  
256

### Flash Mounting Accessories

#### EZR Platform Only (N7063)

The EZ female for the flash; also fits all flash accessories, such as height extenders, Metz adapter platform, Nikon dedicated cord/universal handle mount adapter, replacement shoe, and twin flash bar.

**Item # NEN7063 .....16.95**

#### Flash Accessory Mount (N7064)

Extremely secure. Uses the 1/4" Nice Knurled Knob for high torque retention. Can be used as a tripod spacer.

**Item # NEN7064 .....23.50**

*Twin Flash Bar (N7080)*



*EZ Female Hasselblad (N7071)*

#### EZ Female Standard (N7070)

**Item # NEN7070 .....29.95**

#### EZ Female Hasselblad (N7071)

**Item # NEN7071 .....29.95**

### EZ Female Camera Plates

**EZ Female F3 with Motor (N7072)**  
For the Universal Flash Rotator Bracket.

**Item # NEN7072 .....29.95**

**EZ Female FA/FE/FM with Motor (N7073)**

For the Universal Flash Rotator Bracket.

**Item # NEN7073 .....29.95**

**EZ Female Bronica ETR/S/Si (N7075)**

For the Universal Camera Rotator Bracket. Milled for ETR base, no grip.

**Item # NEN7075 .....29.95**

**EZ Female XL (N7076)**

For very eccentric tripod socket motors.

**Item # NEN7076 .....37.95**

### Miscellaneous Accessories

#### Twin Flash Bar (N7080)

With single sync connector. Accepts two shoe mount flash units. Sync cord included.

**Item # NEN7080 .....56.50**

#### Quantum Battery Holder (N7081)

For the Universal Camera Rotator, Universal Non-Rotator, and the Bronica SQ Bracket.

**Item # NEN7081 .....28.50**

#### EZ Female Bracket Stand (Feet) (N7082)

For the Universal Camera Rotator, Universal Non-Rotator, and Bronica SQ Bracket. Adjustable.

**Item # NEN7082 .....32.50**

#### Nice Knurled Knob (N7090)

Fits Universal and Bronica brackets, tripod EZ mate, EZ male assembly base, and flash accessory mount.

**Item # NEN7090 .....4.95**

ACCESSORY to BRACKET CHART		N7000	N7100	N7200	N7300	N7400
N7080	Twin Flash Bar	•	•	•	•	•
N7037	Canon Dedicated Cord Holder	•	•			
N7036	Handle Mount Platform	•	•	•	•	•
N7039	Flash Shoe	•	•	•	•	•
N7032	1" Tilt Unit	•	•	•	•	•
N7033	2" Tilt Extender	•				
N7034	4" Tilt Extender	•				
N7035	Metz Adapter	•	•	•	•	•
N7030	Overhead Extender	•	•	•	•	
N7031	Forward Extender	•	•	•	•	
N7070	Standard Plate	•	•	•	•	•
N7071	Hasselblad Plate	•	•			
N7072	Nikon F3 w/Motor Plate	•	•			
N7073	Nikon FA/FE w/Motor Plate	•				
N7074	Nikon 8008 Plate	•				
N7075	ETR/ETRS/ETRSi Plate	•				
N7062	EZR Flash Release System	•	•	•	•	•
N7038	Hand Strap	•	•			
N7052	ETRSi w/Speed Grip	•				
N7064	EZ Flash Accessory Mount	•	•	•	•	•
N7081	Quantum Battery Holder	•	•	•	•	
N7082	Bracket Stand	•	•	•		

Technical Advice Available

# BRACKETS

## LINDAHL BRACKET PLUS SYSTEM

The Bracket Plus Systems are designed to be a complete flash bracket system for your 35mm, 6x4.5 or 2¼ square format cameras with a shoe mount type strobe. Designed to be used only with prism finders, the system will allow Bronica ETR(S) and Mamiya 645 users to keep their flash oriented over the lens in both vertical and horizontal positions, casting the shadows behind the subject. Adapters are available for handle mount type strobes, such as a Metz, Sunpak, etc.

**Bracket Plus System for 35mm (171010)**  
Consists of #17-3500 grip and #17-2211 swing arm with shoe mount.  
**Item # LIBPK35.....89.10**

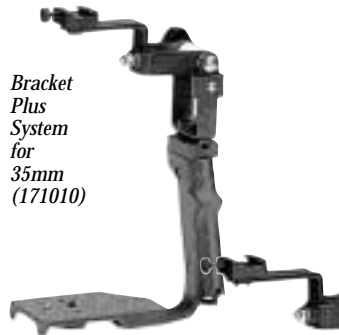

*Bracket Plus System for 35mm (171010)*

**Bracket Plus System for 6x4.5 Format (171510)**  
Consists of #17-2250 grip and #17-2211 swing arm with shoe mount.  
**Item # LIBPK645.....89.10**

**Bracket Plus System for 2¼ (6x6 and 6x7) (172010)**  
Consists of #17-2250 grip and #17-3211 swing arm with shoe mount.  
**Item # LIBPK66.....89.10**

*Bracket Plus System for 6x4.5 format (171510)*

### Lindahl Trigger Grip



The Trigger Grip is a medium format flash bracket with a shutter release designed to make the job easier. The Trigger Grip is a significant improvement over a cable release. Features include a swing arm that allows for flash height adjustability and a shutter release mechanism, which is pressed by the trigger on the grip. Each model is camera-specific with individualized base plates. Designed to work with prism finders, equipment sits solidly upright, even with heavy flash attachments.

**Trigger Grip for Hasselblad (170910)**  
**Item # LIGTH.....121.50**

**Trigger Grip for Mamiya C330/C220 (170913)**  
**Item # LIGTMC330.....121.50**

**Trigger Grip for Mamiya 645 (170911)**  
**Item # LIGTM645.....121.50**

**Trigger Grip for Bronica ETRSi (170914)**  
**Item # LIGTBE.....121.50**

**Trigger Grip for Mamiya RB/RZ (170912)**  
**Item # LIGTMRB.....121.50**

**Trigger Grip for Bronica SQa (170915)**  
**Item # LIGTBS.....121.50**

**Trigger Grip for Rollei 6000 Series (170916)**  
**Item # LIGTR6.....121.50**

**Handle Mount Adapter (171020)**  
Fits on shoe mount. Adjustable and can be used on tube type flashes like Sunpak, Metz, etc.  
**Item # LIHMSA.....12.15**

**Head Mount Adapter (171030)**  
Fits on shoe mount. Used with Lumedyne and Norman head mount flashes. Also acts as a spacer to allow flash to remain in correct position for either vertical or horizontal shots.  
**Item # LIHMA.....12.15**

**Swing Arm Portion 6" with Shoe Mount (173211)**  
6" distance from top of grip to strobe base.  
Replacement on #17-2010.  
**Item # LISAP6.....49.95**



*Head Mount Adapter (171030)*

**Swing Arm Portion 4" with Shoe Mount (171211)**  
4" distance from top of grip to strobe base.  
Replacement on #17-1010.  
**Item # LISAP4.....Disc.**

**Swing Arm Portion 5" with Shoe Mount (172211)**  
5" distance from top of grip to strobe base.  
Replacement on #17-1510.  
**Item # LISAP5.....49.95**

**Bracket Plus Grip Only 35mm (173500)**  
Replacement on #17-1010.  
**Item # LIBP35.....49.95**

**Bracket Plus Grip Only Medium Format (172250)**  
Replacement on #17-1510, #17-2010.  
**Item # LIBPMF.....49.95**

### Lindahl Trigger Grip Accessories

**Locking Shoe (391006)**  
Aluminum accessory shoe with ¼-20 thread for mounting. Side screw allows for locking accessory in shoe.  
**Item # LILS.....9.50**

**Universal Shoe (391014)**  
Universal aluminum accessory shoe with ¼-20 thread for mounting. Universal size allows mounting of most popular flash shoe sizes. Ideal for use with the Locking Foot, or flash with locking device.  
**Item # LIUSGT.....6.95**

**Standard Foot Aluminum (391007)**  
Standard accessory foot. Includes ¼-20 screw for attaching. Requires a locking shoe for secure mounting.  
**Item # LIFA.....5.95**



*Standard Foot Aluminum (391007)*

**Locking Foot (391012)**  
Attaches to any ¼-20 mounting hole. Tighten lock nut against flash, large locking knob tightens foot to any accessory shoe.  
**Item # LILFGT.....8.95**



**Locking Shoe and Standard Foot Aluminum (391005)**  
Combination of 391006 and 391007.  
**Item # LILSF.....13.95**

**Locking Handle Mount Adapter (171030)**  
Designed to be used with Lumedyne and Norman head mount flashes. Adapter acts as spacer to allow correct alignment of flash when using a 6x4.5 format, or to extend flash position over the lens with square format camera system.  
**Item # LIHMA.....12.15**

# BRACKETS

## STROBOFRAME

PRO ACCESSORIES

258

Stroboframe brackets combine camera and flash into an integrated system that permits superb lighting frame after frame. Most Stroboframe brackets for rectangular format cameras have a unique, patented Rotary-Link mechanism. This simple, ingenious system allows instant camera rotation between horizontal and vertical compositions, with a flick of your wrist. Other features include adjustable grips and a tilting flash arm that allows you to control flash angle. The brackets offer superior balance for comfortable, fatigue-free shooting. Stroboframe brackets are made in the USA from superior, aircraft-quality aluminum with a baked-on epoxy finish. The Rotary-Link mechanism pivots on spring-tensioned nylon bearings for smooth, positive operation. Walnut grips are hand-rubbed to a lustrous, long-wearing finish. Premium materials, quality craftsmanship and field-tested engineering assure years of use and dependability.

### RL/SQ Flash Brackets

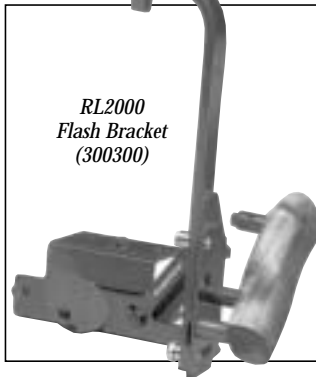

RL2000  
Flash Bracket  
(300300)

**RL 2000 Flash Bracket (300300)**  
For medium format and 35mm cameras. Rotary-link horizontal to vertical camera rotation system. 3-position flash tilt for close-ups. 4-position adjustable side grip with thumb cable release. Tripod mountable. Weighs 21 oz. 10 x 8 x 5" (H.W.D.) Includes 1/4"-20 threaded flash or camera mounts and cable release. (Requires shoe mount, Metz mount or handle mount.)  
**Item # STRL2000 .....96.95**

**Low Profile Camera Platform (300331)**  
For RL 2000, for use with cameras that have a high lens position or an external base-mounted winder. Maintains a centered-under-the-lens position in vertical positions.  
**Item # STCPLPRL2000....14.50**

**Pro-RL Flash Bracket (310-700)**  
For Pro 35 and medium format cameras. Bracket is supported with your left hand leaving your right hand to operate all camera controls including horizontal to vertical positioning. 12 position one-handed flash tilt with flash height from 11 x 18". Dimensions: 14 x 10 x 5.8" HWD. Weighs 33 oz. Tripod mountable. (Requires shoe mount, Metz mount or handle mount.)  
**Item # STPRL.....110.50**

**VH 2000 Vertical/Horizontal Flash Rotator (300100)**  
For medium format and 35mm cameras. Weighs just 9 oz. Designed to be used without handles or cable release. Positions flash above the lens in both horizontal and vertical formats. Flash height adjustment compensates for camera size or use of motor drive. Tripod mountable. 6 x 4 x 5" (H.W.D.). Includes flash shoe and anti-twist plate for 35mm cameras.  
**Item # STVH2000 .....58.95**

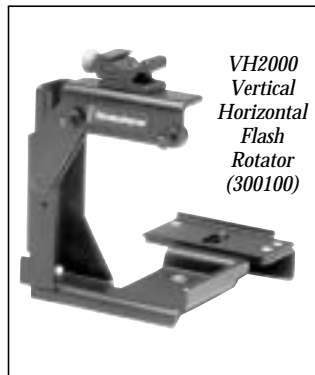

VH2000  
Vertical  
Horizontal  
Flash  
Rotator  
(300100)

**Pro-SQ Flash Bracket (310-705)**  
For square format or rotating back cameras. Same features as Pro-RL but with a fixed camera platform. 14 x 7.5 x 5.8" HWD. Weighs 24 oz. (Requires shoe mount, Metz mount or handle mount.)  
**Item # STPSQ.....96.95**

### R/QR-Series Flash Brackets

**R4-B Bracket (300450)**  
Rotary-link camera platform rotates camera from horizontal to vertical. Keeps lens axis centered under the flash. With walnut center palm grip and two-position side grip. Accepts camera Auto Quick Release and Anti-Twist (AT) Plates. Tripod mountable. Weighs 29 oz. 17 x 7 x 8" (H.W.D.). Includes 1/4"-20 threaded flash mount (requires shoe or Metz mount or handle mount.) and cable release.  
**Item # STR4B .....93.50**

**QR66 Flash Bracket for Hasselblad (300800)**  
Designed by Denis Reggie, for Hasselblad and other square format cameras. Exclusive ultra-thin base design is custom matched to lock into the camera base; prevents twisting. Instant two-position flash angle adjustment for close-ups. Fully cushioned handle for comfortable, fatigue-free shooting and carrying. Bracket will sit upright on flat surfaces with camera and flash attached. Optional cable release kit attaches to foam handle.. Dimensions: 8x5.5x2" (H.W.D.) Weight: 1 lb. 2 oz.  
**Item # STQR66H .....82.95**



QR66 Flash  
Bracket for  
Hasselblad  
(300800)

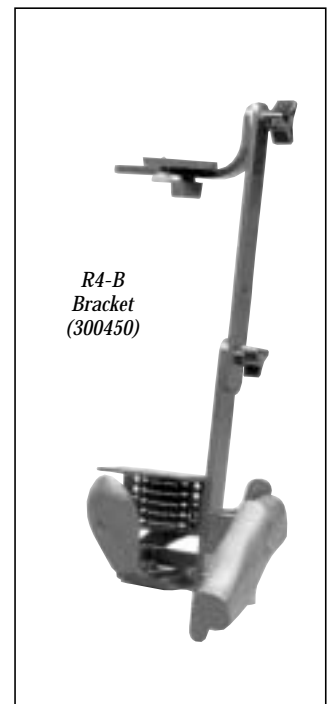

R4-B  
Bracket  
(300450)

**QR66 Cable Release Kit (300810)**  
Attaches to bracket handle. Includes 19" cable release.  
**Item # STCRQR66 .....17.95**

**"Camera Flip" Flash Bracket (310900)**  
For most 35mm and 6x4.5cm camera/shoe mount flash combinations. Allows camera rotation between vertical and horizontal positions while flash remains centered over the lens. Padded foam grip. Accepts camera Auto Quick release and Anti-Twist (AT) Plates. Tripod mountable. Weighs 16 oz. Dimensions are 10.5 x 8x 2.8" HWD. It includes a shoe type flash mount.  
**Item # STCF .....57.93**

# BRACKETS

## STROBOFRAME, *continued*

PRO ACCESSORIES

259

### Quick Flip Flash Brackets

All Strobframe Quick Flip Flash brackets have a pivoting flash arm that keeps the flash over the lens in both horizontal and vertical positions. They have a

#### Quick Flip 350 (310635)

For all 35mm cameras and shoe-mount flash units. Can also be used with handle-type flash (optional 300-HAN). Includes shoe mount. Dimensions: 9 x 9 x 2" (H.W.D.) Weighs just 10oz.

**Item # STQF350.....41.50**

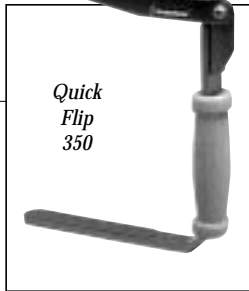

comfortable foam grip and a tripod mountable base. They allow the user to shoot and advance film as if no bracket were attached.

#### Quick Flip 120 (310666)

For all medium format cameras and shoe-mount flash units. Can also be used with handle-type flash (optional 300-HAN). Includes shoe mount. Dimensions: 10x7x4" (H.W.D.) Weighs 12oz.

**Item # STQF120.....48.50**

### Pro-T and Press-T Brackets

The Pro-T and Press-T are flash rotating brackets. Both are light, compact and fast handling. The flash arm swings to keep the flash centered over the lens for both horizontal and vertical compositions. These brackets do not require the use of a cable release. The base mounts directly to the Strobframe Quick Release and accepts all mounts.

#### Pro-T Bracket (310800)

For all medium format and 35mm cameras and all flash units. Flash arm swings clockwise for comfortable vertical shooting. Flash arm has built-in 3° downward tilt in both the horizontal and vertical position to provide better subject illumination. Dimensions are 9½ x 8 x 4½" (H.W.D.) Weighs 14 oz. Includes ¼"-20 threaded flash mount (requires shoe or handle mount for most flashes).

**Item # STPT.....82.95**

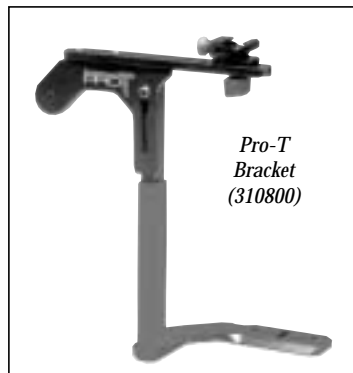

#### Pro-T/M Bracket (310807)

For Mamiya 6, 6MF and Mamiya 7. The base is configured to allow full access to all Mamiya baseplate controls. You can load film and change lenses easily without removing the camera from the bracket! This bracket also has a built-in camera anti-twist system. (Requires shoe or handle mount for most flashes.)

**Item # STPTM7.....96.95**

#### Press-T Bracket (310810)

The Press-T Bracket is a slightly shorter version of the Pro-T, without the 3° tilt. It is popular with photojournalists and other shooters who work out of a camera bag. Its dimensions are 7 x 7 x 4.5", and weighs just 11 oz.

**Item # STSPT.....75.95**

### Specialty Brackets

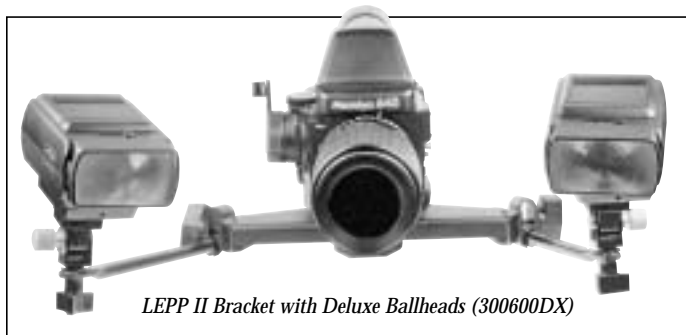

#### LEPP II Dual Flash Macro Bracket (300600)

For 35mm and compact medium format cameras with shoe mount flash units. Two fully adjustable 10" flash arms, with quick-locking knobs. Broad, flat mounting base with stainless steel tripod mount provides a stable, secure camera platform. Supplied with pivoting standard shoe mounts and cork camera pad. Dimensions: 3 x 12 x 10" (H.W.D.) Weighs 12 oz. Comes with two flash shoes.

**Item # STBL2.....82.95**

#### LEPP II Bracket with Deluxe Ballheads (300600DX)

Same as the LEPP II Dual Flash Macro Bracket (300600), with 2 Strobframe Shoe Mount Flash Ballheads. Shoe can be removed to accept ¼"-20 fittings on dedicated flash cords.

**Item # STBL2D.....110.50**

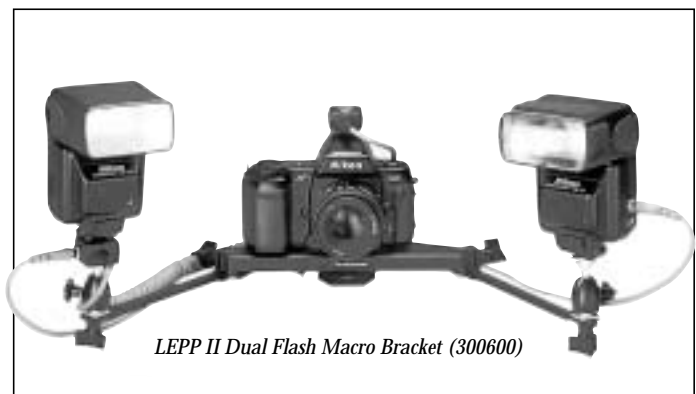

THE PROFESSIONAL'S SOURCE (212) 444-6630 • FAX: (212) 239-7770

1 • 8 0 0 • 9 4 7 • 6 6 5 0

# BRACKETS

## STROBOFRAME, *continued*

PRO ACCESSORIES  
260

### Bracket Accessories

#### Flash Mounts

Stroboframe Brackets accept these interchangeable flash mounts:

**Shoe Type (300SHO)**  
For all standard shoe-type flash units, such as Vivitar 283, etc.  
**Item # STFMS .....9.95**

**Handle-Type (300Han)**  
For all handle-style flash units such as Metz 45, 60 and Sunpak handle mounts.  
**Item # STFMH .....12.95**

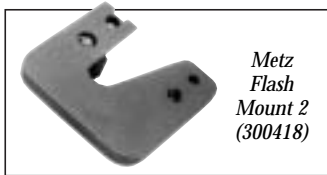

Metz Flash Mount 2 (300418)

**Metz Flash Mount 2 (300418)**  
Adds quick release capability for Metz flash and allows for height adjustment of Metz flash.  
**Item # STFMM2 .....15.95**

**Metz Flash Mount 3 (300428)**  
**Item # STFMM3 .....19.95**

**Metz Flash Mount 4 (300438)**  
**Item # STFMM4 .....19.95**

**1/4"-20 Flash Mounting Knob (903109)**  
For dedicated cords, accessories and flash heads, such as Lumedyne and Norman. Replacement.  
**Item # STMKF .....2.95**

**Stroboframe Cable Release (300409)**  
Vinyl-covered. For all Stroboframe brackets with side grips. Replacement.  
**Item # STCR .....9.95**

**Norman 200B Extra Long Mounting Screw (300413)**  
To mount the Norman 200B or similar separate flash heads having an extra deep socket.  
**Item # STMSN .....1.95**

**Universal Flash Mount Arm (300430)**  
Converts original R4a, R7, R66a, RL/c and Mamiya 6 bracket to accept new Flash Quick Release. Accepts all Stroboframe flash mounts.  
**Item # STFMAU .....13.50**

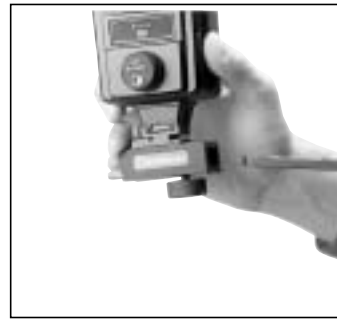

**Flash Quick Release (300QRF)**  
Quickly mounts and dismounts any flash unit onto or off of Stroboframe flash brackets. Accepts Stroboframe shoe and handle-type flash mounts, and any flash with 1/4"-20 thread. Clicks onto flash arm.. Safety spring locks into place. Fits RL2000, SQ2000, R4b, R66b, Pro-T and QR66.  
**Item # STQRF .....24.95**

Flash Quick Release (300QRF) shown with Shoe Type Bracket (300SHO)

#### METZ MOUNT APPLICATION CHART

BRACKET	FOR METZ 45 OR 60	FOR METZ 50-MZ-5	BRACKET	FOR METZ 45 OR 60	FOR METZ 50-MZ-5
RL-2000	Use 300-418	Use 300-428	Press-T	Use 300-418	Not recommended
R4/b	Use 300-418	Use 300-428	Pro-T/m	Use 300-418	Not recommended
Camera Flip	Use 300-418	Use 300-428	Pro-RL	Use 300-438	Use 300-438
QR66	Use 300-418	Use 300-428	Pro-SQ	Use 300-438	Use 300-438
HBG	Use 300-418	Use 300-428	Flash Umbrella	Use 300-418 or	Use 300-418 or
Pro-T	Use 300-418	Not recommended		Use 300-438	Use 300-438

#### Anti-Twist Plates

Register and lock-in camera position. Prevent camera from twisting on bracket platform. Mount via locating pins and lock screw. AT plates are recommended for use with RL2000, SQ2000, R4b, R66b Pro-T, Leap Brackets, Vertaflip PHD and Camera Auto Quick Release. AT Plates are required with Stroboflip VH2000.

#### 35mm CAMERA AT PLATES

MFG #	Description	Item #	Price
300-NF4	For Nikon F4	STATPNF4	10.95
300-BE1	For Nikon N90S, Canon EOS-1N, with BP-E1 and booster	STATPCE1N	10.95
300-NF5	For Nikon F5	STATPNF5	10.95
300-H35	For Nikon N90, and Nikon F4s with MB20 battery	STATPNF4SMB2	10.95
300-SLR	For all other 35mm SLR's	STATP35	10.95

#### MEDIUM FORMAT CAMERA AT PLATES

MFG #	Description	Item #	Price
300-MAM	For Mamiya 645, RB67, RZ67, and C330 models	STATPM	10.95
300-ETR	For all Bronica 6x4.5cm models	STATPBE	10.95
300-SQA	For all Bronica square format models	STATPBS	10.95
300-GS1	For Bronica GS-1	STATPBG	10.95
300-HAS	For all Hasselblad models	STATPH	10.95
300-PTX	For Pentax 645	STATPP645	10.95

#### CAMERA FLASH AT PLATES

<i>(Mount between flash and flash arm to prevent flash from twisting)</i>			
300-C17	For Nikon SC-17 dedicated cord	STATPNSC17	10.95
300-QFL	For Quantum Q-Flash	STATPOQ	10.95
300-LUM	For all Lumedyne flash heads	STATPL	10.95

**Equipment Leasing Available**



# BRACKETS / CONVERTERS

STRATOS BY SEIGELITE

## Modula Flash Bracket System for 35mm and Medium Format Cameras

Stratos brackets are precision machined black anodized 6061 aircraft aluminum. Modular design allows to switch between 35mm and medium format cameras by interchanging length or height posts. Models 1135 & 1200 feature a tilting strob mount with 15° tilt. Anti-fatigue, non-slip contour foam grip (on all models) are one of the most comfortable on the market today. Both the camera mount and the flash mounts are adjustable and the shoe has a built-in quick release. All brackets are designed with the professional in mind.

35mm Bracket  
with 8" Post (SI835)

Item # **STB358** .....**52.95**

35mm Bracket  
with 10" POST (SI1035)

Item # **STB3510** .....**54.95**

35mm Bracket with  
Micro Tilt Adjustment (SI1135)

Item # **STB35MTA** .....**88.95**

Medium format Bracket with  
Micro Tilt Adjustment (SI1200)

Item # **STBMFQ** .....**106.50**

### Stratos Accessories

#### Accessories

8" (20.3cm) Post (SI8P)

Item # **STP8** .....**29.95**

12" (30.5cm) Post (SI12P)

Item # **STP12** .....**33.95**

7 to 11" (17.8-27.9cm)

Adjustable Post (SI7211)

Item # **STPA** .....**53.95**

4" (10.2cm) Extension

for Adjustable Post (SIEAP)

Item # **STEAP** .....**23.95**

Metz Flash Adapter (SIMFA)

Item # **STMFA** .....**29.95**

Metz Sensor Adapter (SIMSA)

Item # **STMSA** .....**19.95**

20" Cable Release  
with Bracket Adapter

Item # **STCR20** .....**22.95**

Non-Rotating  
Arm Adapter (SINRAA)

Item # **STNRAA** .....**27.95**

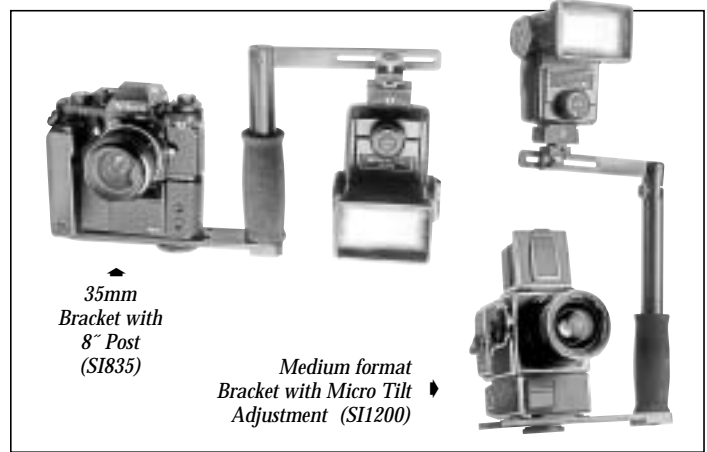

35mm  
Bracket with  
8" Post  
(SI835)

Medium format  
Bracket with Micro Tilt  
Adjustment (SI1200)

### Siegelite

#### M2RT Flash Bracket (M2RT)

Fits most 35mm cameras. Adjustable extension rod for added height. Removable flash shoe holder. 5" long base plate. Built-in tripod socket and PC tip conditioner. Steel stud camera screw. Lightweight - weighs only 12½ oz.

Item # **SIM2RT** .....**64.95**

#### Bracket Umbrella Kit (BRUMK)

Consists of the M2RT bracket, 20" silver umbrella and UHBL umbrella holder.

Item # **SIUK** .....**123.95**



## View Camera Converter for Medium Format Cameras

#### Horseman View Camera Converter Body for Medium Format SLR (21801)

Transforms your medium format SLR to a view camera. The VCC attaches via a special adapter ring. Once in place, the photographer may use swing, tilt, shift and rise and fall movements.

Item # **HOVCC** .....**1,725.00**

#### Camera Mounts

Available for Pentax 67, Pentax 645 and Mamiya 645, which have focal plane shutters, eliminating the need for lens shutter operation.

Pentax 67 Mount (21881)

Item # **HOCMP67** .....**187.95**

Pentax 645 Mount (21882)

Item # **HOCMP645** .....**187.95**

Mamiya 645 Mount (21883)

Item # **HOCMM645** .....**187.95**



VCC Lens Units are available for medium format use. These lenses offer superb image sharpness, color fidelity and freedom from distortion.

#### VCC Lens Unit Rodagon

135mm F5.6 (21853)

Item # **HO13556VCC** .....**697.50**

#### VCC Lens Unit Rodagon

150mm F5.6 (21854)

Item # **HO15056VCC** .....**809.95**

#### VCC Lens Unit Rodagon

180mm F5.6 (21855)

Item # **HO18056VCC** .....**836.95**

### VCC SPECIFICATIONS

#### Usable lenses:

Large format lenses with fringe focal distance between 90mm and 300mm, mounted on #0 or #1 shutter.

**Track Extension:** 72mm

**Tripod Socket:** ¼" Std. thread

**Lens Panel:** 80 x 80mm

#### Camera Movements

(Front Standard):

**Rise:** 14mm, **Fall:** 14mm

**Lateral Shift:** 30mm (L/R) each

**Swing:** 15° (L/R)

**Tilt:** 15° forwards/backwards

**Lateral Shift:** 30mm (L/R)

**Back Swing:** 11° (L/R)

**Back Tilt:** 11° forward/backward

#### Camera Mount:

3 interchangeable mounts

#### Dimensions:

4.8x6.0x5.1" (122x153x130mm)

#### Weight:

2.53 lbs. (1.15kg)



THE PROFESSIONAL'S SOURCE (212) 444-6630 • FAX: (212) 239-7770

1 • 8 0 0 • 9 4 7 • 6 6 5 0

# POUCHES

## ZING, DELTA C.P.M., PERFECTED POUCHES

### Zing Pouches

Zing lens pouches and bags will shield your lens, flash, binoculars or personal stereo from damaging moisture, shock and dirt. The best nylon straps and plastic hardware add the quality touch to Zing's superior products. Accessory bags come standard with a shoulder strap, belt loops and a waist strap/harness. A secure hook and loop fastener keeps your equipment safe inside. Dimensions are 1½ x 5 x 7" (4 x 13 x 18cm).



- |  |  |  |  |
|--|--|--|--|
| Accessory Bag, Blue<br>Item # <b>ZIABBL</b> ... <b>19.95</b> | Accessory Bag, Red<br>Item # <b>ZIABR</b> ..... <b>19.95</b> | Accessory Bag, Green<br>Item # <b>ZIABGR</b> .. <b>19.95</b> | Accessory Bag, Black<br>Item # <b>ZIABB</b> ..... <b>19.95</b> |
|--|--|--|--|

Lens pouches come with a belt loop and a plastic snaphook for easy carrying. A drawstring and a plastic cord-lock secure the pouch closed. Available in black, with a choice of color insides and tops.

**Small Pouch Black/Black**  
5 x 3¼" (12.7 x 8.3cm) HD. Black exterior, black interior.  
Item # **ZIPSB**.....**9.95**

**Small Pouch Purple/Black**  
Same as above with purple interior.  
Item # **ZIPSP**.....**9.95**

**Small Pouch Blue/Black**  
Same as above with blue interior.  
Item # **ZIPSBL**.....**9.95**

**Medium Pouch Black/Black**  
6¾ x 3¼" (17 x 8.3cm) HD. Black exterior, black interior.  
Item # **ZIPMB**.....**10.95**

**Medium Pouch Blue/Black**  
Same as above with blue interior.  
Item # **ZIPMBL**.....**10.95**

**Medium Pouch Purple/Black**  
Same as above with purple interior.  
Item # **ZIPMP**.....**10.95**

**Large Pouch Black/Black**  
9½ x 3¼" (24 x 9.5cm) HD. Black exterior, black interior.  
Item # **ZIPLB**.....**13.95**

**Large Pouch Purple/Black**  
Same as above with purple interior.  
Item # **ZIPLP**.....**13.95**

**Large Pouch Blue/Black**  
Same as above with blue interior.  
Item # **ZIPLBL**.....**13.95**

### Delta C.P.M. ProPouch 911

Stores, protects and organizes your valuable equipment. Perfect for lenses, light meters, film backs, film, filters, etc. High density foam provides maximum insulation and shock protection. Velcro closures. Ultralite is made of strong black parachute nylon with a weight of 2.5 oz. Cordura is a rugged high-abrasion, water resistant pouch for tough handling in any environment.



**ProPouch 911**  
High-abrasion water resistant pouch. Made of rugged cordura. 9 x 11".  
Item # **DEPP911C**.....**23.95**

**ProPouch 911with Lead Shield**  
High-abrasion water resistant pouch with lead shield. Made of rugged cordura. 9 x 11".  
Item # **DEPP911LS**.....**37.95**

### Perfected Film Back Belt Pouches

Now carry that extra roll film magazine or cut film on your belt with safety. Both a spring-clip and a belt-loop are provided.

**Film Back Belt Pouch HMP-1**  
Fits Hasselblad, Bronica ETR and Pentax 645.  
Item # **PEBPHFB**.....**24.95**

**Film Back Belt Pouch MSP-1**  
Fits Bronica SQ, Mamiya Pro and Super.  
Item # **PEBPBSFB**.....**24.95**



**Film Back Belt Pouch MMP-1**  
Fits Mamiya RB, Bronica GS-1 and some pro meters.  
Item # **PEBPBEFB**.....**24.95**

**Film Back Belt Pouch MMP-2**  
Fits Mamiya 645 inserts.  
Item # **PEBPM645I**.....**24.95**

**Film Back Belt pouch MMP-3**  
Fits Mamiya RZ, and light and spot meters.  
Item # **PEBPMRZFB**.....**24.95**

**Film Back Belt Pouch 451**  
Holds four 4x5 cut film holders.  
Item # **PEBPFH45**.....**39.95**

**Film Back Belt Pouch 452**  
Fits Polaroid and NPC backs.  
Item # **PEBPPB**.....**33.50**

### B&H 4x5 Film Holder Pouch

Provides padded protection for up to six 4x5 film holders. It can be closed with Velcro, or zippered shut. A convenient mesh pocket on the front provides storage space for dark slides and accessories. It is constructed of tough denier fabric and ¼" high density padding. Sewn in belt loops allow it to be worn around the waist for quick access to your film holders. Available in black only.



**4x5 Film Holder Pouch**  
Item # **GBCFH45**.....**29.95**

### SeaKing Diver's Dry Box

Keeps your important photographic items dry at depths of up to 30'. Made of high-impact ABS plastic with stainless steel hinge and O-ring seal. Comes with web carrying strap. Dimensions are 5½ x 8½ x 6" DLW. Blue color with translucent top.



**SeaKing Diver's Dry Box**  
Item # **SE585BL**.....**32.50**

For more pouches, see the "Bags and Cases" section of this catalog

Literature Available Upon Request

# POUCHES, PROTECTIVE WRAPS

M C P H O T O G R A P H I C

MC Photographic lens wraps, protective pouches, and camera cases are as tough as they come — on the outside. Inside, they are softies! Thick, shock-absorbing padding is combined with a soft, plush covering. Lens wraps and filter wallets close securely with velcro seals. The padded stuffsacks have a self-locking drawstring. An assortment of bright, recognizable colors, make it easy to locate each protected item. MC Photographic — American made products for the serious photographer.

MC Wraps and Pouches come in many colors. The codes for these colors are as follows:

**Black =B, Grey =G, Green =GR, Light Blue =LB, Light Green =LG Navy =N, Orange =O, Red =R, Tan =T, Yellow =Y.**

To order, please insert color code into blank space.

PRO ACCESSORIES  
263

## Heavy Duty Lens Wraps

Heavy Duty Lens Wraps allow you to pack expensive lenses and light meters quickly and securely. These easy-to-use versatile wraps can protect a variety of shapes.

**Square Lens Wrap (0701\_)**  
11". (28cm).  
**Item # MCLW11\_ .....12.50**

**Square Lens Wrap (0702\_)**  
15". (38cm).  
**Item # MCLW15\_ .....14.95**

**Square Lens Wrap (0703\_)**  
19". (48cm).  
**Item # MCLW19\_ .....19.95**



## Deep Pouches

Deep Pouches are perfect for protecting larger items such as binoculars, CDs, cut film holders or even large format lenses that are mounted onto lens-boards.

**Small Deep Pouch (0730\_)**  
Dimensions: 5½ x 6½ x 1½".  
(14x16.5x3.8 cm).  
**Item # MCDPS\_ .....16.95**

**Medium Deep Pouch (0730\_)**  
Dimensions: 7½ x 8½ x 1½".  
(19x21.6x3.8 cm).  
**Item # MCDPM\_ .....19.95**

## Tough Protective Pouches

Fast and secure, these pouches are perfect for protecting items with sharp corners. They can be used for Polaroid film backs, rollfilm



backs, tripod heads, magnifiers and loupes. The Small and Extra Small pouches are ideal for point and shoot cameras. And, with handy belt loops, carrying compact cameras, binoculars and lightmeters has become easier than ever.

**5x5" Wratten/Cokin Pouch (0705\_)**  
**Item # MCFWC55\_ .....9.95**

**Lightmeter Pouch (0706\_)**  
5½ x 8½". (14 x 21.6cm).  
**Item # MCMP\_ .....14.95**

**Extra Small Pouch (0708\_)**  
4x6". (10.2 x 15.2 cm).  
**Item # MCPP6\_ .....9.95**

**Small Pouch (0709\_)**  
5½ x 6½". (14 x 16.5 cm).  
**Item # MCPP6.5\_ .....13.95**

**Medium Pouch (0710\_)**  
8 x 8". (20.3 x 20.3 cm).  
**Item # MCPP8\_ .....17.50**

**Large Pouch (0711\_)**  
7½ x 10½". (19 x 26.7 cm).  
**Item # MCPP10.5\_ .....18.50**

**X-Large Pouch (0712\_)**  
10 x 10". (25.4 x 25.4 cm).  
**Item # MCPP10\_ .....19.50**

## Stuff Sacks

Stuff sacks provide the needed padding to protect delicate odd shaped equipment that needs to go into bulk type cases. A handy self locking drawstring completes the protection.



**Extra Small Stuff Sack (0704\_)**  
4 x 4 x 9". (10.2x10.2x22.9cm).  
**Item # MCSS449\_ .....14.95**

**Medium Stuff Sack (0720\_)**  
11 x 18 x 11". (27.9 x 45.7 x 27.9cm).  
**Item # MCSS111811\_ .....27.95**

**Small Stuff Sack (0719\_)**  
6 x 12 x 6". (15.2x30.5x15.2cm).  
**Item # MCSS6126\_ .....17.50**

## Film Back Protective Pouches

Same as Tough Protective Pouches, but exclusively for roll film holders and backs.

**Film Back Pouch (0704\_)**  
For 6 x 9 film backs.  
**Item # MCFBP\_ .....17.95**

**Film Back Pouch (0707\_)**  
For 4 x 5 film backs.  
**Item # MCFBP45\_ .....19.95**

**Film Back Pouch (0734\_)**  
For Hasselblad film backs.  
**Item # MCFBPH\_ .....14.50**

**Film Back Pouch (0736\_)**  
For Polaroid film backs. 10½ x 6½". (26.7 x 16.5 cm).  
**Item # MCFBPP\_ .....19.50**

**Film Back Pouch (0737\_)**  
For Calumet C22 film backs. 10½ x 6½". (27.6 x 16.5 cm).  
**Item # MCFBPPCC2\_ .....19.95**

## Mesh-Faced Pouches

Mesh Faced Pouches provide the needed protection for small and odd shaped equipment that needs to go into larger cases. They are see thru and easy to find.

**Flat Zippered Pouch (0714\_)**  
5x7". (12.7x17.8cm).  
**Item # MCP57\_ .....7.95**

**Film Block Pouch (0713\_)**  
8x10x3". (20.3x25.4x7.6cm).  
**Item # MCPFB\_ .....9.95**

**Credential Pouch (0795\_)**  
4¾ x 6½". (12 x 16.5cm).  
**Item # MCCP\_ .....24.95**



THE PROFESSIONAL'S SOURCE (212) 444-6630 • FAX: (212) 239-7770

1 • 8 0 0 • 9 4 7 • 6 6 5 0

# PROTECTIVE WRAPS

## WRAPS, LENS POUCHES

PRO ACCESSORIES

264

### Domke Protective Wraps

Constructed of padded Velcro-compatible knit with a protective backing. These squares can be wrapped around lenses, tools, or anything that will fit inside. Velcro tabs on all four corners allow wrap to be self-secured in any configuration. Available in different colors for quick identification.

11" (28cm) PROTECTIVE WRAP	15" (38cm) PROTECTIVE WRAP	19" (48cm) PROTECTIVE WRAP
Black Protective Wrap Item # DOPW11B.....9.95	Black Protective Wrap Item # DOPW15B.....12.50	Black Protective Wrap Item # DOPW19B.....13.50
Red Protective Wrap Item # DOPW11R.....9.95	Red Protective Wrap Item # DOPW15R.....12.50	Red Protective Wrap Item # DOPW19R.....13.50
Yellow Protective Wrap Item # DOPW11Y.....9.95	Yellow Protective Wrap Item # DOPW15Y.....12.50	Yellow Protective Wrap Item # DOPW19Y.....13.50
Gray Protective Wrap Item # DOPW11G.....9.95	Gray Protective Wrap Item # DOPW15G.....12.50	Gray Protective Wrap Item # DOPW19G.....13.50



### Op/Tech Soft Wrap

Extra protection for lenses, cameras, light meters, small tripods and monopods. An extra 5" pad within the wrap can be moved around to provide added protection. Black exterior, with a choice of interior colors.

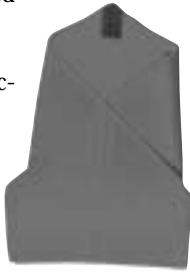

Soft Wrap 11" (28cm) Royal Blue Interior Item # OPSW11RB.....9.95	Soft Wrap 15" (38cm) Royal Blue Interior Item # OPSW15RB.....12.50	Soft Wrap 19" (48cm) Royal Blue Interior Item # OPSW19RB.....13.50
Soft Wrap 11" (28cm) Gray Interior Item # OPSW11G.....9.95	Soft Wrap 15" (38cm) Gray Interior Item # OPSW15G.....12.50	Soft Wrap 19" (48cm) Gray Interior Item # OPSW19G.....13.50
Soft Wrap 11" (28cm) Red Interior Item # OPSW11R.....9.95	Soft Wrap 15" (38cm) Red Interior Item # OPSW15R.....12.50	Soft Wrap 19" (48cm) Red Interior Item # OPSW19R.....13.50
Soft Wrap 11" (28cm) Green Interior Item # OPSW11GR.....9.95	Soft Wrap 15" (38cm) Green Interior Item # OPSW15GR.....12.50	Soft Wrap 19" (48cm) Green Interior Item # OPSW19GR.....13.50

### B&H Lens Wrap

The ultimate protection for lenses, cameras and fragile accessories. Tough denier outer shell, 3/16" open foam interior, and soft tempo lining protects contents. All corners contain Velcro, allowing any corner to be securely fastened onto another. Available in black.



Lens Wrap 15" (38cm) Item # GBLW15.....11.95	Lens Wrap 18" (46cm) Item # GBLW18.....13.95
---	---

Lens Wrap 11" (28cm) Item # GBLW11.....9.95
--

### Delta C.P.M. PhotoWrap

Heavy padded cloth wrap. Completely adjustable with Velcro closures, it affordably protects expensive equipment.

PhotoWrap 19 x 19" Item # DEPW.....14.95
---

### Lens Pouches

B&H lens pouches provide protection for lenses. These cases can be worn on a belt, or Velcro'd to a camera bag strap. The lens pouches also include two compression straps to tighten lenses into lens pouch. They are constructed of tough denier fabric and 1/4" high density padding. Holds lenses with a diameter of up to 4" (10cm). Available in black only.

Lens Pouch 7 1/2" H (21cm) 4" Diameter (10cm) Item # GBLP7.5.....12.95	Lens Pouch 11" H (28cm) 4 3/4" Diameter (12cm) Item # GBLP11.....18.95
--	--

### Galen Rowell Lens Cases

Designed to fit waistbelts, the Galen Rowell lens cases have a double-sewn #8 self-healing zipper, and is made from smooth abrasion-free nylon packcloth material. Compression straps keep the lens from falling out with the top open.

Lens Case 8" H (20cm) 4" Diameter (10cm) Item # GALCB.....12.95	Lens Case 11" H (28cm) 5" Diameter (13cm) Item # GALCLB.....19.95
---	---

We are on the web at: <http://www.bhphotovideo.com>

# LENS CAPS

## GENERIC, TIFFEN LENS CAPS

PRO ACCESSORIES

265

### Snap-On Lens Caps

SIZE	GENERIC BRAND		TIFFEN	
37mm Snap-On Lens Cap	Item # GBLC37	4.95	-	-
40.5mm Snap-On Lens Cap	-	-	Item # TILC40.5	8.95
43mm Snap-On Lens Cap	Item # BOLC43	4.95	-	-
43.5mm Snap-On Lens Cap	Item # BOLC43.5	4.95	-	-
46mm Snap-On Lens Cap	Item # GBLC46	4.95	-	-
48mm Snap-On Lens Cap	Item # GBLC48	4.95	-	-
49mm Snap-On Lens Cap	Item # GBLC49	4.95	Item # TILC49	8.95
52mm Snap-On Lens Cap	Item # GBLC52	4.95	Item # TILC52	8.95
55mm Snap-On Lens Cap	Item # GBLC55	4.95	Item # TILC55	8.95
58mm Snap-On Lens Cap	Item # GBLC58	4.95	Item # TILC58	8.95
62mm Snap-On Lens Cap	Item # GBLC62	5.95	Item # TILC62	9.95
67mm Snap-On Lens Cap	Item # GBLC67	5.95	Item # TILC67	9.95
72mm Snap-On Lens Cap	Item # GBLC72	5.95	Item # TILC72	9.95
77mm Snap-On Lens Cap	Item # GBLC77	5.95	-	-
Pentax 82mm Snap-On Lens Cap	Item # GBLC82	11.95	-	-
Tamron 112mm Snap-On Lens Cap	Item # TALC112	24.95	-	-

### Sima Cap Keepers

Prevents lens cap loss with adhesive-backed disc attached lens cap. CK1 attaches to a strap lug on the camera. CK2 has an elastic band which fits around the lens barrel for use with SLR type cameras. CK3 is a retractable reel type retainer which attaches to the tripod socket. It has attachments for 4 lens caps.



- Cap Keeper 1 (CK1)  
Item # **SICK1** .....**1.99**
- Cap Keeper 2 (CK2)  
Item # **SICK2** .....**1.99**
- Cap Keeper 3 (CK3)  
Item # **SICK3** .....**3.95**

### Metal Filter Stack Caps

Metal Filter Stack Caps protect filters from dust and scratches while they are not being used. Simply screw the filters together, then screw these stack caps on the top and bottom. Great for storing filters when not in use!

- 62mm Stack Cap Set  
Item # **GBSC62** .....**16.95**
- 67mm Stack Cap Set  
Item # **GBSC67** .....**16.95**
- 72mm Stack Cap Set  
Item # **GBSC72** .....**16.95**
- 77mm Stack Cap Set  
Item # **GBSC77** .....**16.95**

### Metal Screw-In Lens Caps

- 46mm Stack Cap Set  
Item # **GBSC46** .....**12.95**
- 48mm Stack Cap Set  
Item # **GBSC48** .....**12.95**
- 49mm Stack Cap Set  
Item # **GBSC49** .....**12.95**
- 52mm Stack Cap Set  
Item # **GBSC52** .....**12.95**
- 55mm Stack Cap Set  
Item # **GBSC55** .....**12.95**
- 58mm Stack Cap Set  
Item # **GBSC58** .....**12.95**

SIZE	GENERIC BRAND	
24mm Cap	Item # BOLCM24	7.95
25.5mm Cap	Item # BOLCM25.5	7.95
30.5mm Cap	Item # BOLCM30.5	7.95
35.5mm Cap	Item # BOLCM35.5	7.95
37.5mm Cap	Item # BOLCM37.5	7.95
39mm Cap	Item # BOLCM39	7.95
40.5mm Cap	Item # BOLCM40.5	7.95
43mm Cap	Item # BOLCM43	7.95
43.5mm Cap	Item # BOLCM43.5	7.95
46mm Cap	Item # GBLCM46	7.95

SIZE	GENERIC BRAND		TIFFEN	
48mm Cap	Item # GBLCM48	7.95	-	-
49mm Cap	Item # GBLCM49	7.95	Item # TILCM49	11.95
52mm Cap	Item # GBLCM52	7.95	Item # TILCM52	11.95
55mm Cap	Item # GBLCM55	7.95	Item # TILCM55	11.95
58mm Cap	Item # GBLCM58	9.95	Item # TILCM58	11.95
62mm Cap	Item # GBLCM62	9.95	Item # TILCM62	14.95
67mm Cap	Item # GBLCM67	9.95	Item # TILCM67	14.95
72mm Cap	Item # GBLCM72	9.95	Item # TILCM72	23.95
77mm Cap	Item # GBLCM77	9.95	Item # TILCM77	23.95
Series 9 Cap	-	-	Item # TILCMS9	32.95



# LENS HOODS

GENERIC BRAND, TIFFEN, HOYA, HAMA

## Rubber Lens Hoods

Prevents light from entering the lens from extreme angles. Can be folded back and left on camera. Double threaded to accept filters.

SIZE	GENERIC BRAND		TIFFEN	
	Item #	Price	Item #	Price
24mm Rubber Lens Hood	GBLH24	5.95	—	—
25.5mm Rubber Lens Hood	GBLH25.5	5.95	—	—
30.5mm Rubber Lens Hood	GBLH30.5	5.95	—	—
37.5mm Rubber Lens Hood	GBLH37.5	5.95	—	—
40.5mm Rubber Lens Hood	GBLH40.5	5.95	TILH40.5	11.95
43mm Rubber Lens Hood	GBLH43	5.95	—	—
43.5mm Rubber Lens Hood	GBLH43.5	5.95	—	—
46mm Rubber Lens Hood	GBLH46	4.95	TILH46	11.95
48mm Rubber Lens Hood	GBLH48	4.95	—	—

SIZE	GENERIC BRAND		TIFFEN	
	Item #	Price	Item #	Price
49mm Rubber Lens Hood	GBLH49	4.95	TILH49	11.95
52mm Rubber Lens Hood	GBLH52	4.95	TILH52	11.95
55mm Rubber Lens Hood	GBLH55	4.95	TILH55	11.95
58mm Rubber Lens Hood	GBLH58	4.95	TILH58	11.95
62mm Rubber Lens Hood	GBLH62	5.95	TILH62	12.95
67mm Rubber Lens Hood	GBLH67	5.95	TILH67	12.95
72mm Rubber Lens Hood	GBLH72	5.95	TILH72	15.95
77mm Rubber Lens Hood	GBLH77	5.95	TILH77	15.95
Series 9 Rubber Lens Hood	—	—	TILHS9	62.95

## Wide-Angle Lens Hoods

Similar to regular collapsible hoods, but designed for wide-angle lenses. Prevent glare and improve contrast in your pictures and slides.

SIZE	GENERIC BRAND		TIFFEN	
	Item #	Price	Item #	Price
46mm Wide-Angle Rubber Lens Hood	—	—	TILHWA46	14.95
49mm Wide-Angle Rubber Lens Hood	GBLHWA49	7.95	TILHWA49	14.95
52mm Wide-Angle Rubber Lens Hood	GBLHWA52	7.95	TILHWA52	14.95
55mm Wide-Angle Rubber Lens Hood	GBLHWA55	7.95	TILHWA55	14.95
58mm Wide-Angle Rubber Lens Hood	GBLHWA58	7.95	TILHWA58	14.95
62mm Wide-Angle Rubber Lens Hood	GBLHWA62	8.95	TILHWA62	15.95
67mm Wide-Angle Rubber Lens Hood	GBLHWA67	8.95	TILHWA67	15.95
72mm Wide-Angle Rubber Lens Hood	GBLHWA72	12.95	TILHWA72	19.95
77mm Wide-Angle Rubber Lens Hood	GBLHWA77	14.95	TILHWA77	19.95
Ser 9 Wide-Angle Rubber Lens Hood	—	—	TILHWAS9	98.95
4 1/2" Wide-Angle Rubber Lens Hood	—	—	TILHWA4.5	98.95

## HAMA Zoom Lens Hoods "Telematic S"

Made of acid-proof, temperature insensitive, matte black rubber. This universal lens hood is adjustable in steps to cover all focal lengths between 24 and 210mm.

	Accepts Filter	Mfr. #	Item #	Price
49mm Zoom Lens Hood	52mm	92949	HALHZ49	19.95
52mm Zoom Lens Hood	55mm	92952	HALHZ52	19.95
55mm Zoom Lens Hood	58mm	92955	HALHZ55	19.95
58mm Zoom Lens Hood	62mm	92958	HALHZ58	19.95
62mm Zoom Lens Hood	67mm	92962	HALHZ62	24.50
67mm Zoom Lens Hood	72mm	92967	HALHZ67	24.50
72mm Zoom Lens Hood	77mm	92972	HALHZ72	24.50
77mm Zoom Lens Hood	77mm	92977	HALHZ77	24.50

## Metal Lens Hoods

Screw-on metal hood for standard and telephoto lenses

SIZE	GENERIC BRAND		TIFFEN	
	Item #	Price	Item #	Price
46mm Metal Lens Hood	—	—	TILHM46	9.95
49mm Metal Lens Hood	GBLHM49	9.95	TILHM49	11.95
52mm Metal Lens Hood	GBLHM52	9.95	TILHM52	11.95
55mm Metal Lens Hood	GBLHM55	10.95	TILHM55	11.95
58mm Metal Lens Hood	GBLHM58	10.95	TILHM58	12.95
62mm Metal Lens Hood	GBLHM62	11.95	TILHM62	14.95
67mm Metal Lens Hood	GBLHM67	12.95	TILHM67	14.95
72mm Metal Lens Hood	GBLHM72	12.95	TILHM72	19.50
77mm Metal Lens Hood	GBLHM77	18.95	TILHM77	19.50
Series 9 Metal Lens Hood	—	—	TILHMS9	62.95
138mm Metal Lens Hood	—	—	TILHM138	218.50
4 1/2" Metal Lens Hood	—	—	TILHM4.5	108.95

## HOYA Multi-Lens Hoods

Protects the lens from direct light. Most suitable for zoom lenses, tele, wide and standard lenses (35mm to 200mm). Easy-to-use.

	Item #	Price
49mm Multi-Angle Rubber Lens Hood	HOLHMA49	15.95
52mm Multi-Angle Rubber Lens Hood	HOLHMA52	15.95
55mm Multi-Angle Rubber Lens Hood	HOLHMA55	15.95
58mm Multi-Angle Rubber Lens Hood	HOLHMA58	15.95
62mm Multi-Angle Rubber Lens Hood	HOLHMA62	19.95
67mm Multi-Angle Rubber Lens Hood	HOLHMA67	19.95
72mm Multi-Angle Rubber Lens Hood	HOLHMA72	19.95
77mm Multi-Angle Rubber Lens Hood	HOLHMA77	19.95

Most Orders Shipped Within 24 Hours

# STEPPING RINGS

## STEP-UP RINGS

### Step-Up Rings

Ultra-thin step-up rings change size of front of camera/lens threads. One size accessory can be used on different size lenses. First size shown screws into your lens, following size is what your new accessory size is now. Step-up rings can also be combined for new accessory size.

SIZE		GENERIC BRAND		TIFFEN	
Lens Thread	Filter Thread	Item #	Price	Item #	Price
25.5mm	to 37mm	GBSUR25.537	9.95	—	—
25.5mm	to 46mm	GBSUR25.546	9.95	—	—
27mm	to 37mm	GBSUR2737	9.95	—	—
27mm	to 46mm	GBSUR2746	9.95	—	—
30.5mm	to 37mm	GBSUR30.537	9.95	—	—
30.5mm	to 46mm	GBSUR30.546	9.95	—	—
32.5mm	to 37mm	GBSUR32.537	9.95	—	—
32.5mm	to 46mm	GBSUR32.546	9.95	—	—
34mm	to 37mm	GBSUR3437	9.95	—	—
34mm	to 46mm	GBSUR3446	9.95	—	—
36mm	to 37mm	GBSUR3637	9.95	—	—
36mm	to 46mm	GBSUR3646	9.95	—	—
37mm	to 37mm	GBSUR3737	5.95	—	—
37mm	to 43mm	GBSUR3743	9.95	—	—
37mm	to 46mm	GBSUR3746	9.95	TISUR3746	8.50
37mm	to 49mm	GBSUR3749	9.95	TISUR3749	11.95
37mm	to 52mm	GBSUR3752	9.95	—	—
37mm	to 58mm	GBSUR3758	9.95	—	—
39mm	to 46mm	GBSUR3946	9.95	—	—
39mm	to 49mm	GBSUR3949	12.95	TISUR3949	11.95
40.5mm	to 46mm	GBSUR40.546	9.95	—	—
40.5mm	to 49mm	GBSUR40.549	9.95	TISUR40.549	11.95
43mm	to 46mm	GBSUR4346	9.95	—	—
43mm	to 48mm	GBSUR4348	9.95	—	—
43mm	to 49mm	GBSUR4349	9.95	TISUR4349	11.95
43.5mm	to 46mm	GBSUR43.546	9.95	—	—
43.5mm	to 48mm	GBSUR43.548	9.95	—	—
46mm	to 48mm	GBSUR4648	5.95	TISUR4648	8.50
46mm	to 49mm	GBSUR4649	5.95	TISUR4649	8.50
46mm	to 52mm	GBSUR4652	5.95	TISUR4652	8.50
46mm	to 55mm	GBSUR4655	5.95	TISUR4655	8.50
46mm	to 58mm	GBSUR4658	5.95	TISUR4658	8.50
48mm	to 49mm	GBSUR4849	5.95	—	—
48mm	to 52mm	GBSUR4852	5.95	TISUR4852	8.50
48mm	to 55mm	GBSUR4855	5.95	TISUR4855	8.50
48mm	to 58mm	GBSUR4858	5.95	TISUR4858	8.50
49mm	to 52mm	GBSUR4952	5.95	TISUR4952	8.50
49mm	to 55mm	GBSUR4955	5.95	TISUR4955	8.50
49mm	to 58mm	GBSUR4958	5.95	TISUR4958	8.50
49mm	to 62mm	GBSUR4962	8.95	TISUR4962	11.95
49mm	to 67mm	GBSUR4967	8.95	TISUR4967	19.95
49mm	to 72mm	GBSUR4972	9.95	TISUR4972	19.95

SIZE		GENERIC BRAND		TIFFEN	
Lens Thread	Filter Thread	Item #	Price	Item #	Price
49mm	to 77mm	GBSUR4977	9.95	TISUR4977	19.95
52mm	to 55mm	GBSUR5255	5.95	TISUR5255	8.50
52mm	to 58mm	GBSUR5258	5.95	TISUR5258	8.50
52mm	to 62mm	GBSUR5262	5.95	TISUR5262	11.95
52mm	to 67mm	GBSUR5267	9.95	TISUR5267	19.95
52mm	to 72mm	GBSUR5272	9.95	TISUR5272	19.95
52mm	to 77mm	GBSUR5277	9.95	TISUR5277	19.95
55mm	to 58mm	GBSUR5558	5.95	TISUR5558	8.50
55mm	to 60mm	GBSUR5560	0.00	—	—
55mm	to 62mm	GBSUR5562	5.95	TISUR5562	11.95
55mm	to 67mm	GBSUR5567	9.95	TISUR5567	19.95
55mm	to 72mm	GBSUR5572	9.95	TISUR5572	19.95
55mm	to 77mm	GBSUR5577	9.95	TISUR5577	19.95
58mm	to 60mm	GBSUR5860	14.95	—	—
58mm	to 62mm	GBSUR5862	5.95	TISUR5862	11.95
58mm	to 67mm	GBSUR5867	9.95	TISUR5867	19.95
58mm	to 72mm	GBSUR5872	9.95	TISUR5872	19.95
58mm	to 77mm	GBSUR5877	9.95	TISUR5877	19.95
60mm	to 62mm	GBSUR6062	14.95	TISUR6062	19.95
60mm	to 67mm	GBSUR6067	14.95	—	—
62mm	to 67mm	GBSUR6267	9.95	TISUR6267	19.95
62mm	to 72mm	GBSUR6272	9.95	TISUR6272	19.95
62mm	to 77mm	GBSUR6277	9.95	TISUR6277	19.95
62mm	to 82mm	GBSUR6282	14.95	—	—
67mm	to 72mm	GBSUR6772	14.95	TISUR6772	19.95
67mm	to 77mm	GBSUR6777	14.95	TISUR6777	19.95
67mm	to 82mm	GBSUR6782	14.95	—	—
67mm	to 95mm	GBSUR6795	39.95	—	—
67mm	to 105mm	GBSUR67105	39.95	—	—
72mm	to 77mm	GBSUR7277	14.95	TISUR7277	19.95
72mm	to 82mm	GBSUR7282	14.95	TISUR7282	28.50
72mm	to 95mm	GBSUR7295	39.95	—	—
72mm	to 105mm	GBSUR72105	39.95	—	—
77mm	to 82mm	GBSUR7782	14.95	TISUR7782	19.95
77mm	to 95mm	GBSUR7795	39.95	—	—
77mm	to 105mm	GBSUR77105	39.95	—	—
82mm	to 95mm	GBSUR8295	39.95	—	—
82mm	to 105mm	GBSUR82105	39.95	—	—
86mm	to 95mm	GBSUR8695	39.95	—	—
86mm	to 105mm	GBSUR86105	39.95	—	—
95mm	to 105mm	GBSUR95105	39.95	—	—
4 1/2"	to 138mm	—	—	TISUR4.5138	219.95



# STEPPING RINGS

## SERIES AND BAYONET STEP-UP RINGS

### Series and Bayonet Step-Up Rings

SIZE		GENERIC BRAND		TIFFEN	
Lens Thread	Filter Thread	Item #	Price	Item #	Price
Series 5	to Series 6	GBSURS5S6	8.95	—	—
Series 5	to Series 7	GBSURS5S7	8.95	—	—
Series 6	to Series 7	GBSURS6S7	8.95	TISURS6S7	19.95
Series 7	to Series 8	GBSURS7S8	8.95	TISURS7S8	19.95
Series 8	to Series 9	GBSURS8S9	17.95	—	—
Series 7	to 55mm	GBSURS755	17.95	TISURS755	19.95
Hasselblad B-50	to 52mm	GBSDRB5052	15.95	—	—
Hasselblad B-50	to 55mm	GBSURB5055	15.95	TISURB5055	15.95
Hasselblad B50	to 58mm	GBSURB5058	15.95	—	—

SIZE		GENERIC BRAND		TIFFEN	
Lens Thread	Filter Thread	Item #	Price	Item #	Price
Hasselblad B50	to 62mm	GBSURB5062	15.95	—	—
Hasselblad B50	to 60mm	GBSURB50B60	39.95	—	—
Hasselblad B60	to 67mm	GBSURB6067	15.95	TISURB6067	28.50
Hasselblad B60	to 77mm	GBSURB6067	24.95	TISURB6077	28.50
Hasselblad B50	to B60	GBSURB50B60	39.95	—	—
Rollei B6	to 67mm	GBSURB667	39.95	—	—
Rollei B6	to 72mm	GBSURB672	39.95	—	—
Rollei B6	to 77mm	GBSURB677	39.95	—	—
Hassel. B60 to Series 8 Adapter Ring		GBARB60S8	39.95	—	—

## ADAPTER RINGS

### Series 7 Adapter Rings

All Series 7 adapter rings come without retaining ring.

30.5mm-S7 Item # <i>GBAR30.5S7</i> .....7.95	43mm-S7 Item # <i>GBAR43S7</i> .....7.95	52mm-S7 Item # <i>GBAR52S7</i> .....9.95	67mm-S7 Item # <i>GBAR67S7</i> .....9.95
34mm-S7 Item # <i>GBAR34S7</i> .....7.95	43.5mm-S7 Item # <i>GBAR43.5S7</i> .....7.95	54/52mm-S7 Item # <i>GBAR5452S7</i> .....9.95	72mm-S7 Item # <i>GBAR72S7</i> .....9.95
35.5mm-S7 Item # <i>GBAR35.5S7</i> .....7.95	46mm-S7 Item # <i>GBAR46S7</i> .....7.95	55mm-S7 Item # <i>GBAR55S7</i> .....9.95	77mm-S7 Item # <i>GBAR77S7</i> .....9.95
37mm-S7 Item # <i>GBAR37S7</i> .....7.95	48mm-S7 Item # <i>GBAR48S7</i> .....6.95	58mm-S7 Item # <i>GBAR58S7</i> .....9.95	Series 7 Retaining Ring Item # <i>GBRRS7</i> .....4.95
40.5mm-S7 Item # <i>GBAR40.5S7</i> .....7.95	49mm-S7 Item # <i>GBAR49S7</i> .....6.95	62mm-S7 Item # <i>GBAR62S7</i> .....8.50	

### Series 5 Adapter Rings

All Series 5 adapter rings come without retaining ring.

24mm-S5 Item # <i>GBAR24S5</i> .....7.95	30.5mm-S5 Item # <i>GBAR30.5S5</i> .....7.95	40.5mm-S5 Item # <i>GBAR40.5S5</i> .....6.95	48mm-S5 Item # <i>GBAR48S5</i> .....6.95
25.5mm-S5 Item # <i>GBAR25.5S5</i> .....7.95	37.5mm-S5 Item # <i>GBAR37.5S5</i> .....7.95	43mm-S5 Item # <i>GBAR43S5</i> .....6.95	Minox GL/GT-S5 Item # <i>GBARMS5</i> .....9.95
27mm-S5 Item # <i>GBAR27S5</i> .....7.95	39mm-S5 Item # <i>GBAR39S5</i> .....6.95	43.5mm-S5 Item # <i>GBAR43.5S5</i> .....6.95	Series 5 Retaining Ring Item # <i>GBRRS5</i> .....4.95
29.5mm-S5 Item # <i>GBAR29.5S5</i> .....7.95		46mm-S5 Item # <i>GBAR46S5</i> .....6.95	

Equipment Leasing Available



# STEPPING RINGS

## STEP-DOWN RINGS

Ultra thin step-down rings change size of front of camera/lens threads. One size accessory can be used on different size lens. When using step-down rings on wide-angle lenses, it is not advised to use much smaller accessories than the lens being used because of possibility of vignetting. First size is the lens thread, following size is the filter thread.

SIZE			GENERIC BRAND		TIFFEN	
Lens Thread	Filter Thread		Item #	Price	Item #	Price
40.5mm	to	37mm	GBSDR40.537	9.95	—	—
43mm	to	37mm	GBSDR4337	9.95	—	—
43.5mm	to	37mm	GBSDR43.537	9.95	—	—
46mm	to	37mm	GBSDR4637	9.95	—	—
46mm	to	40.5mm	GBSDR4640.5	9.95	—	—
46mm	to	43mm	GBSDR4643	9.95	—	—
46mm	to	43.5mm	GBSDR4643.5	9.95	—	—
48mm	to	40.5mm	GBSDR4840.5	9.95	—	—
48mm	to	43mm	GBSDR4843	9.95	—	—
48mm	to	43.5mm	GBSDR4843.5	9.95	—	—
48mm	to	46mm	GBSDR4846	5.95	TISDR4846	8.50
49mm	to	37mm	GBSDR4937	5.95	—	—
49mm	to	46mm	GBSDR4946	5.95	TISDR4946	8.50
49mm	to	48mm	GBSDR4948	5.95	TISDR4948	8.50
52mm	to	46mm	GBSDR5246	5.95	TISDR5246	8.50
52mm	to	48mm	GBSDR5248	5.95	TISDR5248	8.50
52mm	to	49mm	GBSDR5249	5.95	TISDR5249	8.50
55mm	to	46mm	GBSDR5546	5.95	TISDR5546	8.50
55mm	to	48mm	GBSDR5548	5.95	TISDR5548	8.50
55mm	to	49mm	GBSDR5549	5.95	TISDR5549	8.50
55mm	to	52mm	GBSDR5552	5.95	TISDR5552	8.50
58mm	to	46mm	GBSDR5846	5.95	TISDR5846	8.50
58mm	to	48mm	GBSDR5848	5.95	TISDR5848	8.50
58mm	to	49mm	GBSDR5849	5.95	TISDR5849	8.50
58mm	to	52mm	GBSDR5852	5.95	TISDR5852	8.50
58mm	to	55mm	GBSDR5855	5.95	TISDR5855	8.50
60mm	to	55mm	GBSDR6055	14.95	TISDR6055	19.95

SIZE			GENERIC BRAND		TIFFEN	
Lens Thread	Filter Thread		Item #	Price	Item #	Price
62mm	to	49mm	GBSDR6249	6.95	TISDR6249	11.95
62mm	to	52mm	GBSDR6252	6.95	TISDR6252	11.95
62mm	to	55mm	GBSDR6255	6.95	TISDR6255	11.95
62mm	to	58mm	GBSDR6258	6.95	TISDR6258	11.95
67mm	to	52mm	GBSDR6752	10.95	—	—
67mm	to	55mm	GBSDR6755	10.95	—	—
67mm	to	58mm	GBSDR6758	9.95	—	—
67mm	to	62mm	GBSDR6762	9.95	TISDR6762	19.95
72mm	to	55mm	GBSDR7255	14.95	—	—
72mm	to	58mm	GBSDR7258	14.95	—	—
72mm	to	62mm	GBSDR7262	10.95	—	—
72mm	to	67mm	GBSDR7267	10.95	TISDR7267	19.95
77mm	to	62mm	GBSDR7762	10.95	—	—
77mm	to	67mm	GBSDR7767	10.95	—	—
77mm	to	72mm	GBSDR7772	10.95	TISDR7772	19.95
82mm	to	67mm	GBSDR8267	19.95	—	—
82mm	to	72mm	GBSDR8272	19.95	—	—
82mm	to	77mm	GBSDR8277	19.95	—	—
Series 6	to	Series 5	GBSDRS6S5	8.95	TISDRS6S5	8.50
Series 7	to	Series 5	GBSDRS7S5	8.95	—	—
Series 7	to	52mm	GBSDRS7S2	8.95	TISDRS7S2	19.95
Series 7	to	Series 6	GBSDRS7S6	8.95	TISDRS7S6	8.50
Series 8	to	Series 7	GBSDRS8S7	8.95	TISDRS8S7	19.95
Hass B60	to	Hass B50	GBSDRB60B50	39.95	—	—
Hass B60	to	58mm	GBSDRB6058	15.95	—	—
Hass B60	to	62mm	GBSDRB6062	15.95	—	—
Hass B50	to	52mm	GBSDRB5052	15.95	—	—

PRO ACCESSORIES

269

## MACRO COUPLING RINGS

Designed to allow the photographer to face two lenses together, via male-to-male couplers, enabling high quality macro images. It will work by reversing a standard lens to the front of a telephoto lens.

SIZE			GENERIC BRAND	
Lens Thread	Filter Thread		Item #	Price
49mm	to	49mm	GBMC49	7.95

SIZE			GENERIC BRAND	
Lens Thread	Filter Thread		Item #	Price
49mm	to	52mm	GBMC4952	7.95
49mm	to	55mm	GBMC4955	7.95
49mm	to	58mm	GBMC4958	7.95
52mm	to	52mm	GBMC52	7.95
52mm	to	55mm	GBMC5255	7.95
52mm	to	58mm	GBMC5258	7.95

SIZE			GENERIC BRAND	
Lens Thread	Filter Thread		Item #	Price
55mm	to	55mm	GBMC55	7.95
58mm	to	58mm	GBMC58	7.95
62mm	to	62mm	GBMC62	9.95
67mm	to	67mm	GBMC67	9.95
72mm	to	72mm	GBMC72	9.95
77mm	to	77mm	GBMC77	9.95



THE PROFESSIONAL'S SOURCE (212) 444-6630 • FAX: (212) 239-7770

1 • 8 0 0 • 9 4 7 • 6 6 5 0

# STEPPING RINGS

## B + W R I N G S ( S T E P - U P )

Ultra-thin **brass** stepping rings change the size of the front of the camera/lens threads. One size accessory can be used on different size lenses. First size is the lens thread, following size is the filter thread.

PRO ACCESSORIES

270

Lens Thread	SIZE Filter Thread	MFG. CODE	ITEM #	PRICE
18.5	to 19mm	-	BWSUR18.519	43.00
25	to 30.5mm	-	BWSUR2530.5	43.00
30.5	to 35.5mm	-	BWSUR30.535	43.00
30.5	to 39mm	16a	BWSUR30.539	15.00
30.5	to 40.5mm	-	BWSUR30.540	42.00
30.5	to 52mm	-	BWSUR30.552	48.00
32.5	to 39mm	-	BWSUR32.539	43.00
32.5	to 40.5mm	-	BWSUR32.540	42.00
32.5	to 77mm	-	BWSUR32.577	82.00
34	to 58mm	5L	BWSUR3458	15.00
35.5	to 40.5mm	15a	BWSUR35.540	15.00
35.5	to 49mm	9L	BWSUR35.549	15.00
35.5	to 52mm	8f	BWSUR35.552	15.00
35.5	to 58mm	5K	BWSUR35.558	15.00
35.5	to 77mm	-	BWSUR35.577	82.00
36.5	to 39mm	16	BWSUR36.539	15.00
36.5	to 49mm	9K	BWSUR36.549	15.00
39 Coarse	to 40.5mm	15	BWSUR3940.5	15.00
39 Fine	to 40.5mm	15 b	BWSUR3940.5Q	15.00
39	to 41mm	14	BWSUR3941	12.00
39	to 46mm	-	BWSUR3946	43.00
39	to 49mm	-	BWSUR3949	43.00
39	to 52mm	-	BWSUR3952	48.00
39	to 55mm	-	BWSUR3955	48.00
39	to 58mm	5i	BWSUR3958	15.00
40.5	to 40.5mm	-	BWSUR40.540	42.00
40.5	to 43mm	13	BWSUR40.543	15.00
40.5	to 45mm	12	BWSUR40.545	15.00
40.5	to 46mm	11a	BWSUR40.546	15.00
40.5	to 49mm	9i	BWSUR40.549	15.00
40.5	to 52mm	8e	BWSUR40.552	15.00
40.5	to 54mm	7d	BWSUR40.554	15.00
40.5	to 55mm	-	BWSUR40.555	48.00
40.5	to 58mm	5h	BWSUR40.558	15.00
40.5	to 77mm	-	BWSUR40.577	82.00

Lens Thread	SIZE Filter Thread	MFG. CODE	ITEM #	PRICE
41	to 46mm	11	BWSUR4146	15.00
41	to 49mm	9h	BWSUR4149	12.00
41	to 52mm	8d	BWSUR4152	15.00
43	to 49mm	9g	BWSUR4349	15.00
43	to 52mm	8c	BWSUR4352	15.00
43	to 58mm	5g	BWSUR4358	15.00
45	to 49mm	9f	BWSUR4549	13.00
46	to 48mm	10	BWSUR4648	15.00
46	to 54mm	7c	BWSUR4654	15.00
46	to 49mm	9c	BWSUR4649	11.00
46	to 52mm	8b	BWSUR4652	15.00
46	to 55mm	6c	BWSUR4655	10.00
46	to 58mm	5f	BWSUR4658	15.00
46	to 67mm	2h	BWSUR4667	13.00
46	to 77mm	-	BWSUR4677	82.00
46.5	to 49mm	9d	BWSUR46.549	12.00
46.5	to 52mm	8h	BWSUR46.552	15.00
46.5	to 58mm	5e	BWSUR46.558	15.00
48	to 54mm	7b	BWSUR4854	15.00
48	to 49mm	9c	BWSUR4849	11.00
48	to 52mm	8a	BWSUR4852	15.00
48	to 55mm	6b	BWSUR4855	13.00
48	to 58mm	5d	BWSUR4858	15.00
48	to 67mm	2g	BWSUR4867	12.00
49	to 52mm	8	BWSUR4952	10.00
49	to 54mm	7a	BWSUR4954	15.00
49	to 55mm	6a	BWSUR4955	10.00
49	to 58mm	5c	BWSUR4958	10.00
49	to 60mm	4a	BWSUR4960	13.00



**We Exhibit at National and Regional Shows/Conventions**

# STEPPING RINGS

## B + W RINGS (STEP - UP)

Lens Thread	SIZE Filter Thread	MFG. CODE	ITEM #	PRICE
49	to 62mm	3c	BWSUR4962	10.00
49	to 67mm	2e	BWSUR4967	13.00
49	to 72mm	-	BWSUR4972	11.00
49	to 77mm	-	BWSUR4977	11.00
52	to 54mm	7	BWSUR5254	15.00
52	to 55mm	6	BWSUR5255	10.00
52	to 58mm	5b	BWSUR5258	10.00
52	to 62mm	3b	BWSUR5262	10.00
52	to 67mm	2d	BWSUR5267	11.00
52	to 72mm	-	BWSUR5272	12.00
52	to 77mm	-	BWSUR5277	72.00
54	to 55mm	6d	BWSUR5455	15.00
54	to 58mm	5a	BWSUR5458	12.00
55	to 58mm	5	BWSUR5558	10.00
55	to 60mm	4b	BWSUR5560	13.00
55	to 62mm	3a	BWSUR5562	10.00
55	to 67mm	2c	BWSUR5567	11.00
55	to 72mm	-	BWSUR5572	12.00
55	to 77mm	-	BWSUR5577	12.00
58	to 60mm	-	BWSUR5860	48.00
58	to 62mm	3	BWSUR5862	10.00
58	to 67mm	2b	BWSUR5867	11.00
58	to 72mm	1e	BWSUR5872	11.00
58	to 77mm	-	BWSUR5877	12.00
59	to 62mm	3d	BWSUR5962	13.00
60	to 62mm	3e	BWSUR6062	13.00
60	to 67mm	2a	BWSUR6067	42.00
62	to 67mm	2	BWSUR6267	11.00
62	to 72mm	1d	BWSUR6272	11.00
62	to 77mm	1b	BWSUR6277	11.00
67	to 72mm	1c	BWSUR6772	11.00

Lens Thread	SIZE Filter Thread	MFG. CODE	ITEM #	PRICE
67	to 77mm	1	BWSUR6777	11.00
67	to 82mm	-	BWSUR6782	73.00
67	to 105mm	-	BWSUR67105	86.00
72	to 77mm	1a	BWSUR7277	11.00
72	to 82mm	-	BWSUR7282	73.00
77	to 82mm	-	BWSUR7782	73.00
77	to 105mm	-	BWSUR77105	86.00
82	to 86mm	-	BWSUR8286	73.00
82	to 95mm	-	BWSUR8295	73.00
82	to 105mm	-	BWSUR82105	86.00
82	to 127mm	-	BWSUR82127	62.00
85	to 86mm	-	BWSUR8586	73.00
86	to 127mm	-	BWSUR86127	62.00
95	to 105mm	-	BWSUR95105	86.00
95	to 112mm	-	BWSUR95112	86.00
95	to 120mm	-	BWSUR95120	86.00
95	to 127mm	-	BWSUR95127	62.00
100 Fine	to 105mm	0	BWSUR100105	50.00
100 Coarse	to 105mm	00	BWSUR100105Q	50.00
101	to 105mm	-	BWSUR101105	86.00
102	to 127mm	-	BWSUR102127	62.00
105	to 127mm	-	BWSUR105127	62.00
110	to 127mm	-	BWSUR110127	62.00
120	to 127mm	-	BWSUR120127	62.00
127	to 138mm	-	BWSUR127138	86.00
Hass B50	to 52mm	-	BWSDRB5052	20.00
Hass B50	to 55mm	-	BWSURB5055	20.00
Hass B50	to 58mm	-	BWSURB5058	39.00
Hass B60	to 67mm	-	BWSURB6067	40.00
Rollei B6	to 67mm	0a	BWSURB667	50.00
Rollei B6	to 72mm	0b	BWSURB672	50.00
Rollei B6	to 77mm	0c	BWSURB677	50.00
49	to Series 7	-	BWSUR49S7	13.00
52	to Series 7	-	BWSUR52S7	13.00
55	to Series 7	-	BWSUR55S7	13.00
Series 7 Retaining Ring			BWRRS7	9.00



PRO ACCESSORIES

271



THE PROFESSIONAL'S SOURCE (212) 444-6630 • FAX: (212) 239-7770

1 • 8 0 0 • 9 4 7 • 6 6 5 0

# STEPPING RINGS

## B + W RINGS (STEP-DOWN)

PRO ACCESSORIES

272

Ultra thin stepping rings change size of the front of camera/lens threads. One size accessory can be used on different size lens. When using the following rings on wide-angle lenses, it is not advised to use much smaller accessories than the lens being used because of possibility of vignetting. First size is the lens thread, following size is the filter thread.

Lens Thread	SIZE	Filter Thread	MFG. CODE	ITEM #	PRICE
48	to	46mm	-	BWSDR4846	9.00
49	to	27mm	19	BWSDR4927	15.00
49	to	46mm	-	BWSDR4946	9.00
49	to	48mm	-	BWSDR4948	9.00
49	to	49mm	9b	BWSDR4949	15.00
51	to	49mm	9	BWSDR5149	15.00
52	to	46mm	-	BWSDR5246	9.00
52	to	48mm	-	BWSDR5248	9.00
52	to	49mm	28	BWSDR5249	10.00
55	to	46mm	26c	BWSDR5546	12.00
55	to	48mm	26b	BWSDR5548	13.00
55	to	49mm	26a	BWSDR5549	12.00
55	to	52mm	26	BWSDR5552	12.00
55	to	52mm	8i	BWSDR5552Q	12.00
55	to	54mm	27	BWSDR5554	13.00
56	to	52mm	8g	BWSDR5652	15.00
58	to	49mm	25c	BWSDR5849	12.00
58	to	52mm	25b	BWSDR5852	13.00
58	to	55mm	25	BWSDR5855	12.00

Lens Thread	SIZE	Filter Thread	MFG. CODE	ITEM #	PRICE
60	to	52mm	23	BWSDR6052	12.00
60	to	58mm	5m	BWSDR6058	48.00
60	to	59mm	-	BWSDR6059	48.00
62	to	52mm	-	BWSDR6252	11.00
62	to	55mm	-	BWSDR6255	9.00
62	to	58mm	24	BWSDR6258	10.00
62	to	60mm	-	BWSDR6260	51.00
67	to	58mm	-	BWSDR6758	11.00
67	to	62mm	22	BWSDR6762	13.00
72	to	62mm	-	BWSDR7262	58.00
72	to	67mm	-	BWSDR7267	11.00
77	to	67mm	21	BWSDR7767	13.00
77	to	72mm	21a	BWSDR7772	13.00
82	to	77mm	-	BWSDR8277	66.00
105	to	77mm	-	BWSDR10577	86.00
138	to	127mm	-	BWSDR138127	86.00
Hass B60	to	58mm	-	BWSDR6058	48.00
Hass B60	to	62mm	-	BWSDR6062	20.00
Series 7	to	58mm	-	BWSDR5758	12.00
Series 7	to	62mm	-	BWSDR5762	12.00

## HELIOPAN STEP-UP RINGS

Ultra thin brass black finish rings change the front of camera/lens threads. First size is the lens thread, following size is the filter thread.

Lens Thread	SIZE	Filter Thread	MFG. CODE	ITEM #	PRICE
52	to	60mm	700-323	HESUR5260	32.50
55	to	60mm	700-321	HESUR5560	32.50
58	to	60mm	700-320	HESUR5860	32.50
60	to	62mm	700-170	HESUR6062	32.50
60	to	67mm	700-161	HESUR6067	38.50
60	to	72mm	700-651	HESUR6072	39.95
67	to	95mm	700-115	HESUR6795	67.95
67	to	105mm	700-106	HESUR67105	74.50
72	to	95mm	700-114	HESUR7295	67.95
72	to	105mm	700-105	HESUR72105	74.50

Lens Thread	SIZE	Filter Thread	MFG. CODE	ITEM #	PRICE
77	to	82mm	700-130	HESUR7782	54.95
77	to	95mm	700-113	HESUR7795	67.95
77	to	105mm	700-104	HESUR77105	74.50
82	to	95mm	700-112	HESUR8295	67.95
82	to	105mm	700-103	HESUR82105	74.50
86	to	95mm	700-111	HESUR8695	67.95
86	to	105mm	700-102	HESUR86105	74.50
95	to	105mm	700-101	HESUR95105	74.50
Rollei B6	to	67mm	709-904	HESUR667	53.50
Hass B60	to	67mm	709-903	HESUR6067	79.95

*Heliopan Stepping Rings are also available in sizes not listed above.*

**Members of PPA, ASMP, PSA, NPPA and NANPA**

# CLEANING SUPPLIES

## BLOWERS, BRUSHES, CLOTHS, CLEANERS

### Blower



**Hurricane Blower**

All rubber blower. Produces a strong burst of air to clean lenses, cameras, projectors, etc.

**Item # GBBH.....5.95**

### Blower Brushes

Rubber bulb type with protective sleeve. Clean lint and dirt from negatives and camera parts without scratching or smudging.



**Blower Brush, Small**

**Item # GBBBS.....3.50**

**Blower Brush, Medium**

**Item # GBBBM.....3.95**

**Blower Brush, Large**

**Item # GBBBL.....4.95**

### Paper, Chamois, and Cloths

#### Kodak Lens Cleaning Paper

A soft, absorbent paper safe for use on the finest lenses. Lint-free and chemically pure.

Folder contains 50 3x5" sheets.

**Item # KOLT.....1.75**

#### Lens Chamois, 10x10"

Genuine leather, clothing grade. 3 times dry cleaned, oil free. Use over and over.

**Item # GBC1010.....9.95**

#### Ultrafine Lens Cleaning Cloth

Hi-tech optical treatment for removal of residual oil film and microscopic dirt. Cloth is safe for all glass and plastic multi-coated optics. 8x8".

**Item # DECC.....94.95**

### Staticmaster Brushes

Staticmaster Brushes eliminate static electricity and removes dust, lint and other particles in one operation. Emits non-penetrating low-energy alpha particle. They come in 1" and 3" sizes. Cartridges are replaceable.



#### 1" Staticmaster Brush

**Item # STB1.....13.95**

#### 3" Staticmaster Brush

**Item # STB3.....21.95**

#### 1" Cartridge Replacement.

**Item # STC1.....8.95**

#### 3" Cartridge Replacement.

**Item # STC3.....16.95**

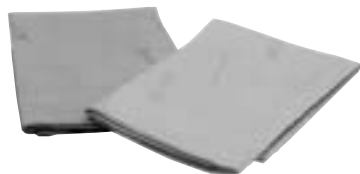

*Falcon Dust-Off Luminex Cloth*

#### Falcon Dust-Off Luminex Ultra Fine Cleaning Cloth

The high-tech way to clean multi-coated lenses. More effective than lens tissue or any other cleaning cloth. 220,000 microfibers per square inch easily lift away dirt, grease and dust. 100% lint-free. Safely cleans any type lens or filter. Washable and reusable. 7½x7½".

**Item # FALC.....4.95**

### Lens Cleaner

Quickly and safely removes foreign matter from the surfaces of all optical glass - smudged, dusty, or fingerprinted camera or enlarger lenses. Supplied in two sizes - 1½ oz. polyethylene squeeze-type bottle, and 16 oz. glass bottle.



#### Kodak Lens Cleaner, 1½ oz.

**Item # KOLC1.250.....2.95**

#### Kodak Lens Cleaner, 16 oz.

**Item # KOLCP.....7.50**



#### R.O.R. Residual Oil Remover

A lens cleaner that aims specifically to remove microcarbon residue which is present on the surface of a lens.

Although invisible to the naked eye, when removed from the lens it provides

a remarkable change and a significant light entry increase (up to 3/4 of an f-stop, in most cases). 2 oz.

**Item # ROROR20.....5.50**

### Camel's Hair Brushes

For removing dust from negatives. A sturdy metal sleeve holds the fine quality bristles firmly. Offers exceptionally long service without shedding.

#### 1" Camel Hair Brush

**Item # GBBCH1.....10.95**

#### 2" Camel Hair Brush

**Item # GBBCH2.....12.95**

#### Edwal Lens Cleaner

Specially formulated to lubricate, as well as clean. Prevents scratches which could result from dust particles held in a dry lens tissue. Completely safe for all coated and uncoated optical glass. Contains no silicon or other film-producing materials. The ¾ oz. squeeze bottle holds enough for 800 clean-ups.

**Item # EDLC.750.....3.95**

#### Rexton Optyl-7 Lens Cleaner

Neutral in PH. Contains no detergents, ammonia or alcohol. Optyl 7 cleans by first binding with the contaminant, then allowing the slurry to be carried away on the lens tissue. It then evaporates without a trace. Optyl-7 does not attack metal or plastics.

**Item # RELC1.....1.50**

#### Rexton Anti-Static Cleaner

Same as the Optyl-7 Lens Cleaner, except it works for film cleaning. 4 oz. bottle.

**Item # REFC40.....3.95**

#### Rexton Anti-Static Cleaner

Same as above. 4 oz. spray for film cleaning.

**Item # REFC4S.....4.95**

#### Rexton Anti-Static Cleaner

Same as above. 16 oz. bottle for film cleaning.

**Item # REFCP.....6.95**

### Kostiner Antistatic Brush

#### Kostiner Short Antistatic Brush

Removes dust and static electricity from plastic, negatives, sheet film, and photographic lenses. Extra-processed acrylic fibers, 35 microns in diameter. Strong yet gentle enough to prevent damage to film. May be washed with soap and water. 4" long carbonized plastic handle, 4" brush.

**Item # KOASBS.....19.95**

# CLEANING SUPPLIES

## BRUSHES, COMPRESSED AIR

### Kintronics Static Wisk Brushes

Dissipate static without radioactive, electric, or electronic devices. Made from natural hair and conductive fibers. May be washed in shampoo and water to clean or vacuumed to remove dust.

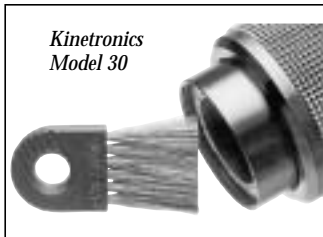

Kintronics Model 30

Kintronics Model 30  
1" plastic handle brush.  
Item # **KIB1** .....**14.95**

Kintronics Model 100N  
4" plastic handle brush.  
Item # **KIB4** .....**19.95**

### Dewitt's Brush

Made of 100% natural boar bristle in a molded nylon handle, Dewitt's Brush looks a lot like an old-fashioned badger-hair shaving brush. The difference is in the boar bristles. They are both stiffer and springier, which is better to get dirt and grit out of hard-to-reach areas. They are feathered at the tip to pick up dust and to protect painted finishes. Ideal for cleaning camera gear and sheet film holder.



Dewitt's Brush  
Item # **VIDB** .....**9.95**

### COMPRESSED AIR

Falcon Dust-Off products are available in two formulas. Dust-Off Special Application Products have been formulated for use in especially sensitive environments, such as scientific research labs and other areas where flammability is a primary concern. All Dust-Off products are not flammable and completely safe for normal use, but they do contain some flammable elements. Both are 100% ozone-safe.

#### Falcon Original Dust-Off

The environmentally safe original Dust-Off formula is used by photographers, computer and office equipment users, service technicians, and lab personnel. Available as a kit containing an 8 oz. can and a chrome nozzle. Optional refills are available separately.



Dust-Off 8 oz. with Chrome Valve Kit  
Item # **FADOK** .....**21.75**

Dust-Off 8 oz. Refill  
Item # **FARDO** .....**6.49**

Dust-Off 8 oz. Refill  
Case of 12.  
Item # **FARDO12** .....**72.95**

#### Dust-Off Mini/Jr.

Available in 1¼ and 3½ oz. sizes, the Mini/Jr's are ideal sizes to carry. The flexible plastic tube can be set in any direction to make hard to reach spots easy to reach.

Dust-Off Mini, 1¼ oz.  
Item # **FADOM** .....**2.95**

Dust-Off Jr, 3½ oz.  
Item # **FADOJ** .....**4.95**

#### Dust-Off Plus

Uniquely designed to get at dust in tough-to-reach places where no ordinary duster can go. Its patented multi-directional 360° Vector Valve® delivers moisture-free blasts. Refills available separately.

Dust-Off Plus 8 oz. with Valve Kit  
Contains 8 oz. refill can and Vector Valve.  
Item # **FADOPKQ** .....**24.95**

Dust-Off Plus 8 oz. Refill  
Item # **FARDOP8** .....**6.95**

Dust-Off Plus 8 oz. Refill  
Case of 12.  
Item # **FARDOP12** .....**79.92**

#### Dust-Off XL

Extra large and extra economical. Provides more blasting power. This convenient disposable 10 oz. can is an ideal work station companion. Also great for on-location photography, laboratories and household use.

Dust-Off XL 10 oz.  
Item # **FADOD** .....**8.95**

#### Dust-Off Pro System

Dusting convenience for studios, darkrooms, mini-labs, repair shops, offices or any active workplace. The Pro Gun and Flexible Hose System provide flexibility for getting dust out of hard-to-reach places, with single-handed operation from any angle. Pro-Gun trigger design lets you control the power, from a gentle puff to a full blast. Complete System includes canister, valve, pro Gun with 8' flexible hose, canister holder and Pro Gun bracket.



Dust-Off Pro System 17 oz.  
Item # **FADOPK** .....**34.95**

Dust-Off Pro 17 oz. Refill  
Item # **FARDOP17** .....**17.95**

#### Dust-Off Accessories

Extension Nozzle  
2' chrome-tipped flexible extension nozzle fits onto standard Dust-Off nozzles and Dust-Off Jr cans to pinpoint the blast in any direction for hard-to-reach areas.



Item # **FAENDO** .....**9.95**

#### Leland Power Clean

Ozone-safe CO<sub>2</sub> dust and particle remover. With variable valve control. Produces 7 times more power than aerosol sprays.

Power Clean Kit (51100)  
1.3 oz. (38 grams).  
Item # **LEPCK** .....**19.95**

Power Clean II Kit (52100)  
2.6 oz. (76 grams).  
Item # **LEPC2K** .....**29.95**

Power Clean Cylinder (51101)  
Power Clean refill.  
Item # **LEPC** .....**6.25**

Power Clean II Cylinder (52101)  
Power Clean II refill.  
Item # **LEPC2** .....**9.95**

# CLEANING SUPPLIES

## COMPRESSED AIR, AIR COMPRESSORS

### Beseler Dust Gun

Beseler's Dust Gun 100 offers a propellant more environmentally safe than ever before. Dust Gun 100 is 100% ozone-safe, non-flammable and contains no ether! Provides the dry, ultra-filtered air to remove even microscopic dust and lint from your negatives, slides and photo or electronic equipment. Meets all federal regulations regarding duster prod-

**Dust Gun 100 (8592)**  
A compact 2½ oz. can with built-in continuously variable trigger with extension nozzle.  
**Item # BEDG1002.5.....3.50**

**Dust Gun 100 (8590)**  
Consists of an 8 oz. can with a built-in continuously-variable trigger valve and extension nozzle.  
**Item # BEDG1008.....4.99**

**Dust Gun 100 (8593)**  
Consists of a 12 oz. can with a built-in continuously-variable trigger valve and an extension nozzle.  
**Item # BEDG10012.....5.99**



**Dust Gun 100 Refill Can (8591)**  
8 oz. refill can. Requires chrome trigger valve.  
**Item # BERDG1008.....4.19**

**Dust Gun 100 Refill Can (8594)**  
12 oz. refill can. Requires chrome trigger valve.  
**Item # BERDG10012.....5.69**

**Dust Gun 100 12-Pack (8591-12)**  
**Item # BERDG100812.....47.95**

**Universal Chrome Trigger Valve (8557)**  
For use with Dust Gun 100 and Dust Gun 22 refills and similar products, such as Falcon, as well as old Freon-12 refill cans.  
**Item # BETV.....16.50**

**Dust Gun 100 8 oz. Kit**  
Consists of chrome trigger valve, with 8 oz. refill can.  
**Item # BEDG1008K.....21.49**

**Dust Gun 100 12 oz. Kit**  
Consists of chrome trigger valve, with 12 oz. refill can.  
**Item # BEDG10012K.....23.45**

### AIR COMPRESSORS

#### Beseler DG-100

A trigger activated pressure switch automatically turns the unit on or off, while directing a air where you need it. Virtually maintenance free and lubricated for life. It is also suitable for airbrush applications.



**DG 100 Deluxe Air Compressor (860301)**  
Includes 12' coiled hose with nozzle, plus pressure switch and in-line on/off switch.  
**Item # BEDG100D.....249.95**

**In-Line Dryer (8604)**  
Filters out unwanted moisture.  
**Item # BEILDDG100.....25.95**

### Professional Motor Drive For Hasselblad Cameras

Transform your manual Hasselblad camera to a motorized camera by simply removing the winding crank, and attaching the Apcam Motor Drive. Enjoy automatic film advance and shutter tensioning on single exposure at a winding speed of approximately one frame per second. Film advancement and shutter cocking is smooth and even. With the electronic "Stop Design", there is no wear on the camera's shutter cocking mechanism. The Apcam Motor Drive is independently powered and ergonomically designed.



**Apcam Motor Drive (500CMX)**  
fits 500C, 500C/M, and 503CX  
**Item # APMDH500C.....499.95**

**Apcam Motor Drive (5013CW)**  
fits 501C, 501C/M, 503CXI and 503CW  
**Item # APMDH501C.....499.95**

### Specifications:

**Winding mode:** Single frame  
**Winding speed:** one frame per second.  
**Attachment:** With securing screw to tripod socket  
**Power source:** 6 AA batteries  
**Power on indication:** Green LED lights up when power is switched on  
**Winding indication:** Red LED lights up during winding cycle or ready to wind  
**Dimensions:** 3.6 x 3.6 x 2.3" (144 x 140 x 90 mm)  
**Weight:** 23 oz. (660g)

# CHANGING ROOMS

## FOCUS CLOTHS, CHANGING BAGS

PRO ACCESSORIES  
276

### Film Changing Bags



Lightweight black nylon outer bag, with an interior bag constructed of rubberized nylon/cotton blend. This affords both light weight, and great opacity. Heavy duty brass zippers hold up over years of use. Double lined, double zipper. Guaranteed light-tight. Rubber wrist bands.

**Small Changing Bag**  
17 x 17" (43 x 43cm).

**Item # GBCBS .....12.95**

**Large Changing Bag**  
27 x 30" (69 x 76cm).

**Item # GBCBL .....21.95**

**Pro Changing Bag**  
36 x 45" (91 x 114cm).

**Item # GBCBP .....44.95**

### C.P.M. Delta Focusing Cloth

Cool, light, durable and snag resistant; one side is white, the other is black. One edge is covered with a Velcro strip allowing the cloth to close around the largest camera or smallest telephoto lens. Each corner has Velcro strips which can be attached to each other or to Velcro weights. 100% cotton.

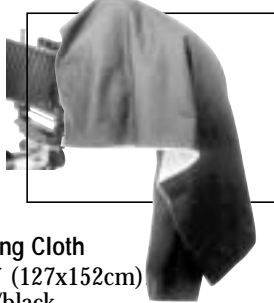

**Focusing Cloth**  
36x50" (91x127cm).  
White/black.

**Item # DEFC3650.....32.95**

**Focusing Cloth**  
50x60" (127x152cm)  
White/black.

**Item # DEFC5060.....33.95**

### Jobo Film Changing Tent

This portable tent has an internal frame that sets up and takes down in just one step. Dual walls with counterdirectional zippers assures a light-tight environment to load your film. The tent is large enough to easily load 8x10" sheet film into a Jobo Expert drum. There are two pockets on the sides to hold your tools (so you don't lose them in the cavernous space!). The tent includes a carrying bag with drawstring. Dimensions: 34.5 x 22 x 24" (88 x 56 x 61cm) HWD.

**Jobo Film Changing Tent**  
With drawstring carry bag.

**Item # JOTFC .....149.95**



**Film Changing Tent for 4x5 (SB22)**  
With Stuff Sack. Designed for 4x5 and smaller film formats. Features a working area of 22 x 22" and an interior height of 15".  
**Item # VICT45 .....193.50**

**Film Changing Tent for Motion Picture (SB3040)**  
Same as above with a working area of 30 x 40".  
**Item # VICTMP.....296.95**

### Focusing Cloths



Focusing cloth for view cameras features double black nylon material and allows the cloth to drape naturally over the sides. It has a special elastic and Velcro band, which fits over the rear standard on most view cameras, to prevent cloth from falling.

**Focusing Cloth**  
36 x 58" (91 x 147cm).

**Item # GBFC3658.....16.95**

**Focusing Cloth**  
58 x 72" (147 x 183cm).

**Item # GBFC5872.....29.50**

### Changing Room

The Photoflex Changing Room is a double walled, light tight changing bag with an internal frame that provides plenty of room to work. You can even change 8x10" film. Also included is an internal, removable "trash bag" so you can keep film wrappers, boxes or canisters away from your film; and the Changing Room sets up/tears down instantly.



*Photoflex Changing Room  
Insert: Shown in carry bag*

Double walled sleeves with elastic knit cuffs keep light out while letting you work in comfort. Sets up to 25 x 22 x 15" L.W.H. (64 x 56 x 38cm) and folds to 19" diameter (48cm).

**Photoflex Changing Room with Carrying Pouch**

**Item # PHCR .....79.95**

### Shadow Box

Eliminates the headache of loading sheet film holders on location. Its self-supporting tent-like construction keeps top and sides away from the work surface. The right choice for loading film into daylight processing tanks when a darkroom is unavailable, it can be used even in direct sunlight without the risk of fogging. White exterior reflects light to keep the inside cool. Coated durable rip-stop nylon interior eliminates the lint that plagues old-fashioned floppy bags.

**Film Changing Tent for 8x10 (SB30)**  
With Stuff Sack. Designed for 8x10 format and motion picture film magazines. Features a working area of 30 x 30" and an interior height of 20".  
**Item # VICT81 .....242.95**

**Literature Available Upon Request**



# CABLES

## CABLES / AIR RELEASES

PRO ACCESSORIES

277

### Cloth Cable Release

Black, cloth covered, metal braided cables with plunger set-screw lock for time exposures.



- 10" Cloth Cable Release  
*Item # GBCRC10* .....**4.95**
- 20" Cloth Cable Release  
*Item # GBCRC20* .....**6.95**
- 40" Cloth Cable Release  
*Item # GBCRC40* .....**9.95**

### Metal Cable Release

Metal woven cable releases with set-screw lock for time exposures.

- 12" Metal Cable Release  
*Item # GBCRM12* .....**8.95**
- 20" Metal Cable Release  
*Item # GBCRM20* .....**9.95**

### Deluxe Vinyl Cable Releases

Vinyl covered metal cable, grip with oversized metal center lock.

- 10" Deluxe Vinyl Cable Release  
*Item # GBCRVCL10* .....**11.95**
- 20" Deluxe Cable Release  
*Item # GBCRVCL20* .....**13.95**
- 40" Deluxe Vinyl Cable Release  
*Item # GBCRVCL40* .....**17.95**
- 60" Deluxe Vinyl Cable Release  
*Item # GBCRVCL60* .....**24.95**

### Deluxe Pro Cable Releases

Wide collar to provide a sure finger-grip, durable black fabric case, and spiral reinforcement of the nipple to prevent kinking. With automatic lock for time exposures.

- 20" Professional Cable Release  
*Item # GBCRP20* .....**29.95**
- 40" Professional Cable Release  
*Item # GBCRP40* .....**34.95**



### Kaiser Cable Release

20" (50cm) Professional Cable Release (206184)  
Consists of two parts; one an upper part with formed grip and auto lock disc; two, a lower portion which is an interchangeable release with black covering and threaded rotating tip.  
*Item # KACR20* .....**34.50**

### Air Shutter Release

Remote control shutter release for most cameras. Strong enough for use with all cameras. Bulb and 20' of tubing (3' and 17' sections on reel) and plunger for Compur.

- 20' Air Shuttle Release  
*Item # GBAR20* .....**11.95**

### Hama/Rowi Pneumatic Releases

Complete with reeling drum from which the tubing can be quickly unwound to the required length.

- Hama 20' (6m) Air Release  
*Item # HAAR20* .....**32.95**
- Hama 33' (10m) Air Release  
*Item # HAAR30* .....**39.95**
- Rowi 20' (6m) Air Release  
*Item # ROAR20Q* .....**19.95**
- Rowi 33' (10m) Air Release  
*Item # ROAR33* .....**33.50**

### Hama Electronic Release

This wired remote release controls electronically triggered cameras which use a 2.5mm standard mini jack.



- Hama 32' Electronic Release (5372)  
*Item # HACRE32* .....**23.95**

### Rowi Twin Cable Release



For synchronizing firing of two cameras, controls automatic diaphragm and shutter, and for use with extension rings and bellows attachments without automatic diaphragm transmission. Black cloth sheath and thumbscrew lock, 20".  
*Item # ROCRT* .....**53.50**

### Cable Release Accessories

**U-Hook Adapter**  
U-shaped. Allows cable release to fit into tight spots, such as on view camera lens/shutter.  
*Item # GBUHA* .....**9.95**

**Universal Self-Timer**  
For cameras without built-in self timers. Screws into camera's shutter release button. Up to 18 second delay, variable if desired. Comes with Leica adapter.  
*Item # GBST* .....**19.95**



**Hama Self Timer** (5401)  
Same as above. 10 seconds. Plunger travel is adjustable to between 0.12" and 0.315". With stop button. Supplied in a case.  
*Item # HAST* .....**39.95**

**Hama L-Shaped Adapter for Cable Release** (5128)  
For medium-format cameras. Rotating nipple ensures easy attachment to the cable release socket, if not easily accessible.  
*Item # HACRAL* .....**14.95**

**Leica Cable Release Adapter "Leica-Nippel"** (5125)  
Designed for Wirgin Edixa and early Leica cameras with external cable release thread. Compatible with all cable releases.  
*Item # HACRALQ* .....**4.95**



THE PROFESSIONAL'S SOURCE (212) 444-6630 • FAX: (212) 239-7770

1 • 8 0 0 • 9 4 7 • 6 6 5 0

# FILM BACKS

## FILM HOLDERS

### Wista 4x5 Film Backs

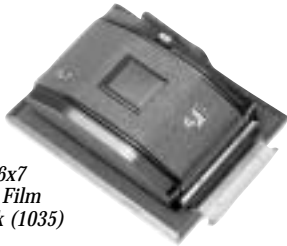

45/6x7  
Roll Film  
Back (1035)

The Wista 4x5 roll film backs attach to the camera instead of to the 4x5 back without groundglass. The roll film back is built onto a 4 1/4 x 6 1/4" (120 x 157mm) plate.

**45/6x7 Roll Film Back (1035)**  
120 film, 6x7cm, 10 exposures.  
**Item # WIFB67120G.....389.95**

**45/6x9 Roll Film Back (1034)**  
120 film, 6x9cm, 8 exposures.  
**Item # WIFB69120G.....389.95**

**45/6x9 Roll Film Back (1033)**  
220 film, 6x9cm, 16 exposures.  
**Item # WIFB69220G.....429.95**

International Standard Roll Film Backs (1036, 1037) for 4x5 field cameras are used when the groundglass is not removed. The roll film back is built onto a 4 1/4 x 6 1/4" (120x157mm) plate and slides into the place of a cut film holder.

**Field 45/6x7 Roll Film Back (1037)**  
120 film, 6x7cm, 10 exposures.  
**Item # WIFB6745DX.....389.95**

**Field 45/6x9 Roll Film Back (1036)**  
120 film, 6x9cm, 8 exposures.  
**Item # WIFB6945DX.....389.95**



Field  
45/6x7 Roll  
Film Back (1037)

### CUT FILM HOLDERS

Double sided. All metal inner core – no wooden parts to break. Interlocking joints.

#### Fidelity Cut Film Holders

**2 1/4 x 3 1/4" Cut Film Holder (2)**  
**Item # FIFH23.....59.95**

**3 1/4 x 4 1/4" Cut Film Holder (2)**  
**Item # FIFH34.....67.50**

**4x5" Cut Film Holder (2)**  
**Item # FIFH45.....33.00**

**5x7" Cut Film Holder (2)**  
**Item # FIFH57.....51.50**

**8x10" Cut Film Holder (2)**  
**Item # FIFH81.....109.50**

**8x10" Cut Film Holder (2)**  
With unbreakable darkslide.  
**Item # FIFH81U.....177.95**

**11x14" Cut Film Holder (2)**  
**Item # FIFH11.....637.95**

**11x14" Cut Film Holder (2)**  
With unbreakable darkslide.  
**Item # FIFH11U.....697.95**



#### Fidelity Dark Slides

**2 1/4 x 3 1/4" Dark Slide Plastic Replacement.**  
**Item # FIDS23.....7.95**

**3 1/4 x 4 1/4" Dark Slide Plastic Replacement.**  
**Item # FIDS34.....7.95**

**4x5" Dark Slide Plastic Replacement.**  
**Item # FIDS45.....7.95**

**5x7" Dark Slide Plastic Replacement.**  
**Item # FIDS57.....9.95**

**8x10" Dark Slide Plastic Replacement.**  
**Item # FIDS810.....14.95**

**11x14" Dark Slide Plastic Replacement.**  
**Item # FIDS11.....24.95**

**8x10" Dark Slide Unbreakable. Replacement.**  
**Item # FIDSU81.....24.95**

**11x14" Dark Slide Unbreakable. Replacement.**  
**Item # FIDSU11.....34.50**

#### Lisco Regal Double-Sided Cut Film Holders

**2 1/4 x 3 1/4" Cut Film Holder (2)**  
**Item # LIFH23.....59.95**

**3 1/4 x 3 1/4" Cut Film Holder (2)**  
**Item # LIFH34.....67.50**

**4x5" Cut Film Holder (2)**  
**Item # LIFH45.....33.00**

**5x7" Cut Film Holder (2)**  
**Item # LIFH57.....51.50**

**8x10" Cut Film Holder (2)**  
**Item # LIFH81.....109.50**

**8x10" Cut Film Holder (2)**  
With unbreakable dark slide.  
**Item # LIFH81U.....177.95**



#### RiteWay Double-Sided Cut Film Holder

**4x5" Cut Film Holder (2)**  
**Item # RIFH45.....46.00**

### Horseman 4x5 Film Backs

Film backs for 4x5" cameras feature ratchet advance and automatic counter resetting. There are backs for 120 and 220 film and a 6x12 for panoramic photography. They are designed to fit all 4x5" cameras that follow the accepted international standard.

**Roll Film Holder 451 (22451)**  
6x9cm. 8 exposures on 120 roll film.  
**Item # HOFB6912045 ...469.00**

**Roll Film Holder 452 (22452)**  
6x7cm.10 exp. on 120 roll film.  
**Item # HOFB6712045 ...469.00**

**Roll Film Holder 453 (22453)**  
6x9cm. 16 exposures on 220 roll film.  
**Item # HOFB6922045 ...469.00**



**Roll Film Holder 454 (22454)**  
6x7cm. 20 exposures on 220 roll film.  
**Item # HOFB6722045 ...469.00**

**Roll Film Holder 612 (22461)**  
6x12cm. 6 exp. on 120 roll film.  
**Item # HOFB61245.....849.00**

**Format Mask Set (23870)**  
For 6x7, 6x9 and 6x12cm. roll film. Supplied as a set.  
**Item # HOFMS.....29.95**

Overnight Shipping Available

# FILM BACKS

## FOR INSTANT FILM

### NPC 3 1/4 x 4 1/4 Instant Film Backs for Medium Format

Accepts Polaroid 3 1/4 x 4 1/4" pack film. Provides instant images in the format size of the camera. They have convenient holders for their stainless steel dark slides. Fast and easy to attach and remove from your camera.

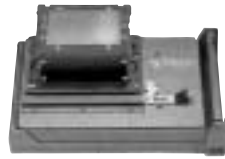

*Polaroid Back Pro MF-21*

**Polaroid Back MF-1**  
Fits all Hasselblad cameras except EL and superwide versions. Compatible with every prism ever made for Hasselblad cameras.  
*Item # NPFBPB* .....**224.95**

**Polaroid Back MF-16**  
Fits Fuji GX-680.  
*Item # NPFBPFGX680* ..**234.95**

**Polaroid Back MF-2**  
Uses thin Fiber-Optic. Fits every Hasselblad body including the EL and superwide cameras.  
*Item # NPFBPBHQ* .....**349.95**

**Polaroid Back MF-17**  
Fits Mamiya 645 Pro.  
*Item # NPFBPM645* .....**269.95**

**Polaroid Back MF-3**  
Fits Mamiya RB-67, Pro-S and SD.  
*Item # NPFBPMRB* .....**179.95**

**Polaroid Back Pro MF-21**  
Fits Pentax 6x7.  
*Item # NPFBPP67* .....**729.95**

**Polaroid Back MF-4**  
Fits Mamiya RZ-67.  
*Item # NPFBPMRZ* .....**179.95**

**Polaroid Back Pro MF-22**  
Fits Mamiya 6 and 7.  
*Item # NPFBPM6* .....**929.95**

**Polaroid Back MF-5**  
Fits Bronica ETR-S & Si.  
*Item # NPFBPBE* .....**154.95**

**Polaroid Back Pro MF-23**  
Fits Fuji 690 GWIII, 690 GSWIII, 670 III.  
*Item # NPFBPFG70* .....**1,169.95**

**Polaroid Back MF-14**  
Fits Bronica SQ-A & SQ-AI.  
*Item # NPFBPBS* .....**174.95**

**Polaroid Back Pro MF-24**  
Fits Pentax 645.  
*Item # NPFBPP645* .....**1,234.95**

**Polaroid Back MF-15**  
Fits Bronica GS-1.  
*Item # NPFBPBG* .....**194.95**

**Polaroid Back MF-524**  
For Hasselblad 500CM, 503CX, 2003FCW, and 2000 FCM. Uses 4x5 film pack. Two images per frame..  
*Item # NPFBPBHQ* .....**349.95**

**Extra Hinge for MF-21, Pentax 6x7 Proback**  
*Item # NPHPB67* .....**89.95**

### NPC 4x5 Instant Film Back Adapters for Medium Format

Works coincide with Polaroid 545 4x5 sheet film holder. Provides instant images in the format size of the camera.

*Polaroid Back Adapter MF-32A shown on Mamiya RZ.*



**Polaroid Back MF-32A**  
Fits Mamiya RZ-67.  
*Item # NPFBP45MRZ* ...**209.95**

**Polaroid Back MF-33A**  
Fits Mamiya RB-67.  
*Item # NPFBP45MRB* .....**209.95**

**Polaroid Back MF-34A**  
Fits Mamiya RB and RZ. Includes T-77 RZ to RB adapter plate.  
*Item # NPFBP45MRZQ* .....**284.95**

### NPC 4x5 Instant Film Backs for Medium Format

Complete with built-in Polaroid 545 4x5 sheet film holder. Provides instant images in the format size of the camera.

**Polaroid Back MF-32**  
Fits Mamiya RZ-67.  
*Item # NPFBP45HMRZ* .....**349.95**

**NPC Polaroid Back MF-35**  
Fits Polaroid 600SE, 203 and 403 miniportrait.  
*Item # NPFBP45HP600* ...**269.95**

**Polaroid Back MF-33**  
Fits Mamiya RB-67.  
*Item # NPFBP45HMRB* .....**349.95**

**NPC Polaroid Back MF-36**  
Fits Fuji 680.  
*Item # NPFBP45HFGX6* ..**349.95**

**Polaroid Back MF-34**  
Fits Mamiya RZ67 and RB-67. Includes T-77 RZ to RB adapter plate.  
*Item # NPFBP45HMRZQ* .....**424.95**



*NPC Polaroid Back MF-32*

### Polaroid Large Format Instant Film Backs



*Polaroid 545i*

**Polaroid 405 Pack Film Holder**  
Fits all international standard 4x5 backs. Accepts polaroid 3 1/4 x 4 1/4" pack film. Provides 2.9x3.8" (7.4x9.7cm) images. They are used to check lighting exposure, composition and to evaluate color.  
*Item # PO405* .....**74.95**

**Polaroid 550 Pack Film Holder**  
For use with 4x5 cameras. Features larger image area, 3 1/4 x 4 5/8" (8.3x6.9cm). Accepts Polaroid 4x5 pack films.  
*Item # PO550* .....**124.50**

**Polaroid 545i Sheet Film Holder**  
For use with 4x5 cameras. Features 3 1/4 x 4 1/2" (8.9x11.4cm) image area. Accepts Polaroid 4x5 sheet film and allows changing of film type after each exposure.  
*Item # PO545I* .....**144.95**

**Fuji Quickload Film Holder**  
For use with Fuji Quickload 4x5 film. Light and compact construction with one-touch automatic lock. Fits on almost all 4x5 cameras.  
*Item # FUFHQL* .....**104.95**

**Kodak Readyload Packet Film Holder**  
For use with Kodak Readyload Packets. Accepts preloaded Kodak Readyload Packets which can be loaded in daylight. This packet film holder fits on virtually any 4x5 camera.  
*Item # KOFHRL* .....**49.95**

**Polaroid Back MF-35A**  
Fits Polaroid 600SE, 203 and 403 Miniportrait.  
*Item # NPFBP45P600* .....**166.50**

**Polaroid Back MF-36A**  
Fits Fuji 680.  
*Item # NPFBPFGX680Q* .**209.95**

**T-77 Adapter Plate**  
Allows use of RZ-67 backs with RB-67.  
*Item # NPAPT77* .....**137.95**

# FILM BACKS

## BEATTIE LONG ROLL BACK FOR MAMIYA RB/RZ

PRO ACCESSORIES

280

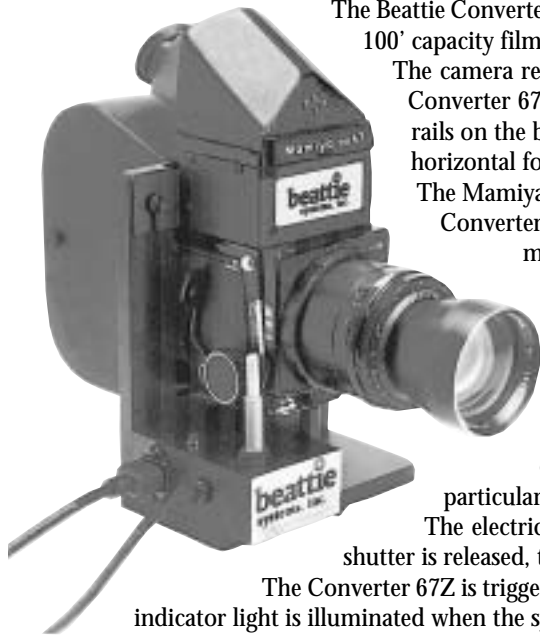

The Beattie Converter 67 is designed to enable the Mamiya RB67 or RZ67 to operate as a long roll camera with 100' capacity film magazines. This allows hundreds of shots to be taken without changing film.

The camera requires no modification whatsoever. The Mamiya RB67 is mounted to four pins on the Converter 67 equivalent to those on the RB67 revolving adapter. The magazine slides into mounting rails on the back of the Converter 67, where a rotating ring allows easy rotation between vertical and horizontal formats.

The Mamiya RZ67 is mounted to the converter by a camera mount screw. The film magazine for the Converter 67Z is modified by permanent incorporation of the Mamiya "G" adapter into the magazine aperture plate for convenient mounting and rotation.

A basic Converter 67 unit consists of two components in addition to the camera: The Converter unit and a film magazine available in a choice of four formats (6x7cm, split 70mm, 46mm and non-perf 35mm). Options available include an adapter to elevate a prism viewfinder above the film magazine and an in-magazine negative identifier.

The Manual Converter 67M system is operated entirely by hand including cocking the camera, tripping the shutter, pushing the ID button and advancing the film. This unit is particularly useful outdoors, or where AC power is not available.

The electric Converter 67E requires cocking the camera and tripping the shutter manually. As the shutter is released, the id (if used) is applied and the film advances automatically.

The Converter 67Z is triggered and cocked by hand. After the camera is tripped, the film advances automatically. An indicator light is illuminated when the system is ready for operation.

The Converter 67Z Power Winder allows the camera to be tripped remotely. The camera automatically cocks and resets itself. The film automatically advances and is ready for the next frame.

### Converter Units

<b>Converter 67 Manual</b> (67001M)	<b>Converter 67 Electric</b> (67001E)	<b>Converter 67Z</b> (68001)
<b>Item # BEC67M.....517.50</b>	<b>Item # BEC67E.....697.50</b>	<b>Item # BEC67Z.....529.95</b>

### FILM BACKS

100' Precision cast aluminum film backs are secured with an easy on/off mechanism. They all feature a 3-digit film counter and can be used with daylight load spools or darkroom load cores. A signal from the film back disables the camera and triggers a warning light when the supply runs out. Film can be cut and removed in changing bags with partial use of the roll.

For Manual Converter RB	For Electric Converter RB		For Electric Converter RZ
<b>D-67 Back</b> (94587M) Uses 70mm film. Image area is 2 <sup>3</sup> / <sub>8</sub> x2 <sup>1</sup> / <sub>16</sub> " (6x7cm). <b>Item # BEFBD6767M.....607.50</b>	<b>D-67 Back</b> (94587X) Uses 70mm film. Image area is 2 <sup>3</sup> / <sub>8</sub> x2 <sup>1</sup> / <sub>16</sub> " (6x7cm). <b>Item # BEFBD6767E.....709.95</b>	<b>46mm F-80 Back</b> (93328X) Uses 46mm film. Image area is 1.63x2.25" (4.1x5.7cm). <b>Item # BEFBF8067E.....709.95</b>	<b>D-67 Back</b> (68067) Uses 70mm film. Image area is 2 <sup>3</sup> / <sub>8</sub> x2 <sup>1</sup> / <sub>16</sub> " (6x7cm). <b>Item # BEFBD6767Z.....889.95</b>
<b>Split 70 D-56 Back</b> (93329M) Uses 70mm film. Image area is 2.5x1.7" (6.4x4.3cm). <b>Item # BEFBD5667M.....607.50</b>	<b>Split 70 D-56 Back</b> (93329X) Uses 70mm film. Image area is 2.5x1.7" (6.4x4.3cm). <b>Item # BEFBD5667E.....709.95</b>	<b>35mm C-55 Back</b> (93324X) Uses 35mm unperforated film. <b>Item # BEFBC5567E.....709.95</b>	<b>Split 70 D-56 Back</b> (68070) Uses 70mm film. Image area is 2.5x1.7" (6.4x4.3cm). <b>Item # BEFBD5667Z.....889.95</b>
<b>46mm F-80 Back</b> (93328M) Uses 46mm film. Image area is 1.63x2.25" (4.1x5.7cm). <b>Item # BEFBF8067M.....607.50</b>	<i>Electric backs are also available in 240v AC. Add \$67.50</i>		<b>46mm Back</b> (68046) Uses 46mm film. Image area is 1.63x2.25" (4.1x5.7cm). <b>Item # BEFBF8067Z.....889.95</b>
<b>C-55 Back</b> (93324M) Uses 35mm unperforated film. <b>Item # BEFBC5567M.....607.50</b>			<i>Electric backs are also available in 240v AC. Add \$67.50</i>
<i>Assorted Beattie Film Backs</i>			

**We Ship Worldwide**

# FILM BACKS

## BEATTIE LONG ROLL BACKS, *continued*

### NEGATIVE IDENTIFICATION FILM BACKS

One option is negative identification backs that allow you to insert a card or an envelope into the slot on the side of the camera. This permits you to place a name or preprinted number within a 2 x 1/2" writing area that will appear on the film. This unit is battery-powered for C-67M, AC powered for C-67E and C67Z models.

#### Negative ID Backs for Manual Converter RB

- D-67 Battery Edge ID Back**  
(94587M) (06715010)  
**Item #**  
**BEFBD67ID67M .....1,079.95**
- 46mm F-80 Battery-Between-Frame ID Back** (93328M) (06715034)  
**Item #**  
**BEFBF80ID67M .....1,079.95**
- Split 70 D-56 Battery Edge ID Back** (93329M) (06715010)  
**Item #**  
**BEFBD56ID67M .....1,079.95**
- 35mm C-55 Battery-Between-Frame ID Back** (93324M) (06715033)  
**Item #**  
**BEFBC55ID67M.....1,079.95**

#### Negative ID Backs for Electric Converter RB

- D-67 Electric Edge ID Back**  
(94587X) (06715000)  
**Item #**  
**BEFBD67ID67E.....1,182.50**
- 46mm F-80 Electric-Between-Frame ID Back** (93328X) (06715024)  
**Item #**  
**BEFBF80ID67E..1,182.50**
- Split 70 D-56 Electric Edge ID Back** (93329X) (06715000)  
**Item #**  
**BEFBD56ID67E.....1,182.50**
- 35mm C-55 Electric-Between-Frame ID Back** (93324X) (06715023)  
**Item #**  
**BEFBC55ID67E 1,182.50**

#### Negative ID Backs for Electric Converter RZ

- D-67 ID Back** (68067) (06715000)  
**Item #**  
**BEFBD67ID67Z1,362.50**
- Split 70 D-56 ID Back** (68070) (06715000)  
**Item #**  
**BEFBD56ID67Z1,362.50**
- 46mm ID Back** (68046) (06715000)  
**Item #**  
**BEFBF80ID67Z.1,362.50**
- Electric ID Backs are also available in 240v AC. Add \$67.50*

- Intenscreen Plus Focusing Screen for Mamiya RB67** (83300)  
**Item #**  
**BEFSOMRB .....119.50**
- Intenscreen Plus Focusing Screen for Mamiya RB-67 in Frame** (83310)  
**Item #**  
**BEFSMRB.....146.95**
- Intenscreen Plus Focusing Screen for Mamiya RZ-67** (83320)  
**Item #**  
**BEFSMRZ.....146.95**

#### Optional Accessories

- Adapter for Mamiya Prism Viewfinder RB-67** (67100)  
**Item #**  
**BEAMPF67M.....174.95**
- Adapter for Mamiya Prism Viewfinder RZ-67** (68200)  
**Item #**  
**BEAMP.....224.95**
- Finder Mask - Vertical/ Horizontal (Specify Format)** (93409)  
**Item #**  
**BEM67.....11.95**
- Viewing Slide** (17550)  
**Item #**  
**BEVSD.....74.95**
- Power Cable with Fuse** (5549000)  
**Item #**  
**BEPCM.....44.95**
- Heavy Duty Shipping/Carrying Case** (180781)  
**Item #**  
**BECM .....241.95**

#### Horseman 2 1/4" Film Backs

Horseman 2 1/4" roll film backs feature smooth, positive film transport, maintain plane film surface and eliminate interior light reflections. Horseman film holders are easy to use. They are professionally designed and built to the highest quality standards, ensuring excellent film plane flatness.



- Roll Film Holder 1** (22401)  
6x9cm. 8 exposures on 120 roll film.  
**Item #**  
**HOFB69120VH..399.00**

- Roll Film Holder 2** (22402)  
6x7cm. 10 exposures on 120 roll film.  
**Item #**  
**HOFB67120VH...399.00**

- Roll Film Holder 3** (22403)  
6x9cm. 16 exposures on 220 roll film.  
**Item #**  
**HOFB69220VH..399.00**

- Roll Film Holder 4** (22404)  
6x7cm. 20 exposures on 220 roll film.  
**Item #**  
**HOFB67220VH..399.00**

#### Toyo Film Backs

Film backs for 2x3 cameras fit onto all Toyo quick sliding carriage adapters, as well as directly onto the Toyo 23G and 6x9cm Graflock backs. The film backs for 4x5" cameras can be inserted into any standard 4x5" camera back without removal of the focusing frame, just as when using an ordinary cut film back.

- 6x7 Roll Film Holder** (180-727; 8032)  
For 2x3. Fits 23G or quick sliding carriage.  
**Item #**  
**TOFB67120SA...499.95**

- 6x9 Roll Film Holder** (180-728; 8034)  
For 2x3. Fits 23G or quick sliding carriage.  
**Item #**  
**TOFB69120SA...499.95**



- 6x7 Roll Film Holder** (180-725; 8031)  
For 4x5.  
**Item #**  
**TOFB6712045 ....599.00**

- 6x9 Roll Film Holder** (180-726; 8033)  
For 4x5.  
**Item #**  
**TOFB6912045 ....599.00**



THE PROFESSIONAL'S SOURCE (212) 444-6630 • FAX: (212) 239-7770

1 • 8 0 0 • 9 4 7 • 6 6 5 0

# ACCESSORIES

## A C C E S S O R I E S

PRO ACCESSORIES

282

### Quick Stick

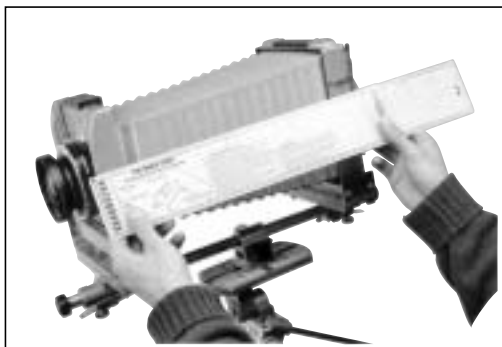

For computing bellows and lens extension corrections. Quick Stick gives corrections directly in stops. All three Quick Stick models are calibrated in  $\frac{1}{8}$  and  $\frac{1}{4}$  stops, and show correction as high as 5 stops (for repro ratios better than 2:1).

- Quick Stick for 35mm and 2 $\frac{1}{4}$ " Square (QS1)  
Item # **VIQS66** ..... **11.95**
- Quick Stick for 4x5" (QS2)  
Item # **VIQS45** ..... **31.95**
- Quick Stick for 4x5 and 8x10" (QS3)  
Item # **VIQSM810** ..... **47.95**

### Depth-of-Field Finder

**Depth of Field Finder (DFF1)**  
Slide rule-style measuring device that tells you the depth-of-field you'll get with all popular 4x5 format lenses. Contains scales for 75, 90, 120, 150, 165, 180, 210, 300, and 360mm focal lengths. Indicates apertures from f/22 to f/64. Includes simple instructions for determining hyperfocal distance.  
Item # **VIFDOF** ..... **27.95**

### Color Separation Guides

**Kodak Color Separation Guide and Gray Scale Small Q13 (152-7654)**  
With Kodak Gray Scale and Color Control Patches. The gray scale is a strip of 20 stepped, neutral values and an 18% gray background that will help compare tone values of the original with the reproduced image. For copy-work, side-by-side comparisons of films, enlarging papers and color reproduction processes that require the use of masks, separation films and filters. Useful for photographers utilizing the Zone system. The Color Control Patches are for photos that will be used in web offset printing. Contains standard separation colors used in RGB and CMYK processes, that helps match the color in the reproduction to the original. They can also be used in comparing the relative reproduction characteristics of different films and papers. 8.5" .  
Item # **KOCSGS** ..... **18.50**



**Kodak Color Separation Guide and Gray Scale Large Q14 (152-7662)**  
Same as above but 14 inches.  
Item # **KOCSGL** ..... **25.95**

### Spirit Levels

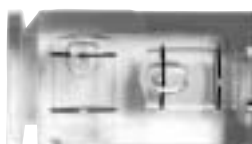

Hama  
2-Bubble  
Spirit  
Level

- Hama 2-Bubble Spirit Level (5411)**  
A precision-made block containing two bubbles in a transparent housing, and with foot for accessory shoe. 1.3 x 0.75 x 0.9".  
Item # **HASLD** ..... **32.95**
- Hama Single Spirit Level (5410)**  
Same as the Hama 2-Bubble Spirit Level, with only one single spirit level.  
Item # **HASLS** ..... **23.50**

### Lens Spanner Wrench

**Lens Spanner Wrench**  
Lens Spanner Wrench is used for installing or removing mounting rings on view camera lenses. Adjustable up to 3".  
Item # **KALSW** ..... **44.95**

**Toyo Lens Mounting Wrench (180625)**  
For mounting and dismounting lenses with #0 and #1 shutters on any lensboard.  
Item # **TOLMW** ..... **11.95**



Toyo  
Lens  
Mounting  
Wrench  
(180625)

### BULK LOADERS

#### 70mm Bulk Loaders

- 70mm Metal Cassette 15'**  
With reel.  
Item # **GBCM70** ..... **38.95**
- Hasselblad 70mm Film Cassette**  
For 70 back.  
Item # **HAFCFB70** ..... **38.95**

#### Alden 70mm Daylight Bulk Loaders

Accepts 100' roll bulk film in regular or 150' thin film. Reloads 70mm cassettes in any footage you want. Daylight loading, with safety interlock to bulk film compartment. Won't scratch film. Indicates film being put on cassette, and film lift in supply chamber. Orange knobs, dials and crank made of Eastman plastic. No felt light trap which may scratch film.



**Alden 70mm Bulk Loader**  
Item # **ALBL70** ..... **129.95**

#### Kinderman 70mm Film Developing System

A 70mm bulk film loader used for spooling 70mm film in cassette. The film loader can also be used as a reel loader for film processing. 5 $\frac{1}{2}$ " H x 7 $\frac{1}{2}$ " diam. (14x19cm).

**Kinderman 70mm Film Loader (EKM217)**  
Item # **KIL70** ..... **179.00**

**Linhof Bulk Film Loader (002513)**  
Item # **LIBFL70** ..... **833.95**

# MISCELLANEOUS

## LEVELS, WRENCHS, BUSHINGS, GRAY CARDS

### 18% Gray Cards

Correct exposure every time regardless of contrast, brightness or conditions. For color or black & white. Includes protective reusable zip lock pouch. Available in 2-pack standard card stock and Lifetime Plastic Gray Card. Both are 8"x10" size.

#### Kodak Gray Cards R-27

Helps determine exposure, lighting ratio, and lighting distribution. 18% reflectance – gray side; 90% reflectance – white side. Envelope contains two 8x10" cards and a 4x5" card, plus instructions.

**Item # KOGC.....14.95**

#### Gray Card 2-Pack 8"x10"

**Item # DEGC2.....7.99**

#### Gray Card Plastic 8"x10"

**Item # DEGCP.....7.99**

### Tripod Bushings

#### Tripod Bushings

Tripod bushing adapters are used when a camera comes with 3/8" tripod thread and 1/4" tripod screw is being used.

**Item # GBRB .....1.95**

#### Professional Adapter Bushing

Stainless steel double slotted. Same as above.

**Item # BRB.2538SS.....8.95**

#### Linhof Brass Bushing (004262)

**Item # LIRB.....8.95**



#### Gitzo Brass Bushing 4.6mm

**Item # GIG1140.....3.50**

#### Gitzo Brass Bushing 7.5mm

**Item # GIG1141.....3.50**

#### Gitzo Brass Bushing 8.6mm

**Item # GIG1142.....3.50**

#### Gitzo Brass Bushing 10mm

**Item # GIG1143.....3.50**

#### Sinar Reducing Bushing 3/8" to 1/4"

The Sinar Reducing Bushing is designed to be installed in the rail clamp from the top down, not from the bottom up. This allows greater security when using the 1/4" thread.

**Item # SIRB.....12.95**

### Camera Key

#### Camera Key (PK-1)

For all Hasselblad cameras. Recocks lenses when off the camera body and recocks the camera body when the lens is jammed on the camera.



#### Please Note:

Hasselblad suggests that this product be used only when the user understands proper use and potential damage from misuse.

**Item # VICK.....29.00**

### Markers, Pencils and Cleaners

#### White Grease Pencil

**Item # GBGPW.....0.79**

#### Black Grease Pencil

**Item # GBGPB.....0.79**

#### Blue Grease Pencil

**Item # GBGPBL.....0.79**

#### Red Grease Pencil

**Item # GBGPR.....0.79**

#### Jobo Color Control Card

Contains six gray patches, and primary and secondary color patches. By taking a picture of the card in each roll of film, you have a known color and density reference point. Folds to 4.5 x 6.6". (11.4 x 16.9cm) Produced from durable plastic. Easily cleaned with a damp cloth.

**Item # JOCCC.....19.95**

#### MacBeth Color Checker

An array of 24 printed color squares, which include spectral simulations of light and dark skin, foliage, etc. Use for precise color balance when shooting color film. 9x13 proportions fill a 35mm frame.

**Item # MACC.....39.95**

#### Pec-Pen

Fine tipped permanent marker for prints and negatives, etc. Quick drying and easily removed with Pec-12.

**Item # PHPPQ.....1.10**

#### Pec-12 Pump Spray Bottle

4 oz. pump spray bottle.

**Item # GBP1240.....9.95**

### Batteries



#### A76 (LR44) Alkaline Battery 1.5v

**Item # GB76A.....1.49**

#### MS76 (SR44)

Silver Oxide Battery 1.5v

**Item # GB76S.....3.50**

#### 2L76 (2LR44)

Lithium Battery 3v

**Item # GB76L.....4.95**

#### PX28 (4LR44)

Alkaline Battery 6v

**Item # GB28A.....6.95**

#### PX28 (4SR44)

Silver Oxide Battery 6v

**Item # GB28S.....7.95**

#### PX28 (544L) Lithium Battery 6v

**Item # GB28L.....9.95**

#### AA (L92) Lithium Battery 1.5v

**Item # GBAAL.....2.75**

#### AA Rechargeable

Nicad Battery

**Item # GBAAN.....2.49**

#### AA (E91) Alkaline Battery 1.5v

**Item # GBAA.....0.59**

#### AAA (E92)

Alkaline Battery 1.5v

**Item # GBAAA.....0.89**

#### C (E93) Alkaline Battery 1.5v

**Item # GBC.....1.19**

#### D (E95)

Alkaline Battery 1.5v

**Item # GBD.....1.29**

#### 9v (MN1604)

Alkaline Battery

**Item # GB9V.....1.99**

#### CR 2025 3v Lithium Battery

**Item # GBCR2025.....1.79**



THE PROFESSIONAL'S SOURCE (212) 444-6630 • FAX: (212) 239-7770

1 • 8 0 0 • 9 4 7 • 6 6 5 0

# FOCUSING SCREENS

## BEATTIE INTENScreens FOR FIELD & VIEW CAMERAS

Intenscreen Plus screens provide extra brightness, better resolution and contrast, or "snap" focus. Tests indicate a light transmission gain of up to 2 f/stops for Intenscreens over Fresnel screens in most cameras. All models combine a special image surface with a high quality corrective field lens (fresnel). They may be a two piece unit or be cast in one piece. Either way, you will receive the best optical focusing screen available.

INTENSREEN FOR 4x5"	MATTE PLAIN		1CM GRID SCREEN		½" GRID SCREEN		PRICE
	(MFG)	ITEM #	(MFG)	ITEM #	(MFG)	ITEM #	
Calumet 400	(85102)	BEFSC400	(85101)	BEFSG1C400	(85100)	BEFSG.5C400	174.95
Calumet 540	(85112)	BEFSC540	(85111)	BEFSG1C540	(85110)	BEFSG.5C540	174.95
Cambo 4x5	(85122)	BEFSC45	(85121)	BEFSG1C45	(85120)	BEFSG.5C45	174.95
Deardorf 4x5	(85132)	BEFSD45	(85131)	BEFSG1D45	(85130)	BEFSGD.545	174.95
Horseman 4x5	(85142)	BEFSH45	-	-	(85140)	BEFSG.5H45	184.95
Linhof 4x5	(85152)	BEFSL45	-	-	(85150)	BEFSG.5L45	174.95
Plaubel 4x5	(85162)	BEFSP45	(85161)	BEFSG1P45	(85160)	BEFSG.5P45	174.95
Sinar 4x5	(85172)	BEFSS45	(85171)	BEFSG1S45	(85170)	BEFSG.5S45	184.95
Toyo 4x5	(85182)	BEFST45	(85181)	BEFSG1T45	(85180)	BEFSG.5T45	184.95
Wista Field 4x5	(85192)	BEFSWF45	(85191)	BEFSG1WF45	(85190)	BEFSG.5WF45	174.95
Wista View 4x5	(85202)	BEFSWV45	(85201)	BEFSG1WV45	(85200)	BEFSG.5WV45	174.95
Wisner 4x5	(85212)	BEFSW45	(85211)	BEFSG1W45	(85210)	BEFSG.5W45	174.95
Zone VI 4x5	(85222)	BEFSZ645	(85221)	BEFSG1Z645	(85220)	BEFSG.5Z645	174.95



Viewed with a standard screen

Viewed with a Beattie Intenscreen

INTENSREEN FOR 5x7"	MATTE PLAIN		½" GRID SCREEN		PRICE
	(MFG)	ITEM #	(MFG)	ITEM #	
Calumet 5x7	(86102)	BEFSC57	(86100)	BEFSGC57	187.95
Cambo 5x7	(86122)	BEFSC57Q	(86120)	BEFSGC57Q	187.95
Deardorf 5x7	(86132)	BEFSDD57	(86130)	BEFSGDD57	187.95
Horseman 5x7	(86142)	BEFSH57	(86140)	BEFSGH57	187.95
Linhof 5x7	(86152)	BEFSL57	(86150)	BEFSGL57	187.95
Plaubel 5x7	(86162)	BEFSP57	(86160)	BEFSGP57	187.95
Sinar 5x7	(86172)	BEFSS57	(86170)	BEFSGS57	187.95
Toyo 5x7	(86182)	BEFST57	(86180)	BEFSGT57	187.95
Wista Field 5x7	(86192)	BEFSWF57	(86190)	BEFSGWF57	187.95
Wista View 5x7	(86202)	BEFSWV57	(86200)	BEFSGWV57	187.95
Wisner 5x7	(86212)	BEFSW57	(86210)	BEFSGW57	187.95
Zone VI 5x7	(86220)	BEFSZ657	(86222)	BEFSGZ657	187.95

INTENSREEN FOR 8x10"	MATTE PLAIN		½" GRID SCREEN		PRICE
	(MFG)	ITEM #	(MFG)	ITEM #	
Calumet 8x10	(88102)	BEFSC810	(88100)	BEFSGC810	198.95
Cambo 8x10	(88122)	BEFSC810Q	(88120)	BEFSGC810Q	198.95
Deardorf 8x10	(88132)	BEFSD810	(88130)	BEFSGD810	198.95
Horseman 8x10	(88142)	BEFSH810	(88140)	BEFSGH810	199.95
Linhof 8x10	(88152)	BEFSL810	(88150)	BEFSGL810	198.95
Plaubel 8x10	(88162)	BEFSP810	(88160)	BEFSGP810	198.95
Sinar 8x10	(88172)	BEFSS810	(88170)	BEFSGS810	199.95
Sinar P2 8x10	—	—	(88171)	BEFSGP2S810	199.95
Toyo 8x10	(88182)	BEFST810	(88180)	BEFSGT810	199.95
Wista Field 8x10	(88192)	BEFSWF810	(88190)	BEFSGWF810	198.95
Wista View 8x10	(88202)	BEFSWV810	(88200)	BEFSGWV810	198.95
Wisner 8x10	(88212)	BEFSW810	(88210)	BEFSGW810	198.95
Zone VI 8x10	(88222)	BEFSZ6810	(88220)	BEFSGZ6810	198.95

All items are complete with all accessories as supplied by the manufacturer



# FOCUSING SCREENS

## BEATTIE INTENSSCREENS FOR MEDIUM FORMAT

Intenscreen Plus screens provide extra brightness, better resolution and contrast, or "snap" focus. Tests indicate a light transmission gain of 2 f/stops for Intenscreens Plus over standard screens in most cameras. All models combine a special image surface with a high quality corrective field lens (fresnel). They may be a two piece unit or be cast in one piece. Either way, you will receive the best optical focusing screen available.

INTENSSCREEN PLUS FOR	MATTE PLAIN		MATTE WITH GRID		HORIZONTAL SPLIT IMAGE PLAIN		PRICE
	(MFG)	ITEM #	(MFG)	ITEM #	(MFG)	ITEM #	
Bronica ETR/ETRS/ETRSi	(83410)	BEFSBE	(83411)	BEFSGBE	(83412)	BEFSSIHBE	134.95
Bronica SQ/SQ-A/SQ-Ai/SQ-AM	(83400)	BEFSBS	(83401)	BEFSGBS	(83402)	BEFSSIHBS	112.95
Bronica GS-1	(83420)	BEFSBG	(83421)	BEFSGBG	(83422)	BEFSSIHBG	103.95
Fuji G617/GX617	(83710)	BEFSFG617	(83711)	BEFSGFG617	—	—	187.95
Fuji GX-680	(83700)	BEFSFGX680	(83701)	BEFSGFGX680	(83702)	BEFSSIHFGX68	142.95
Hasselblad 500CM, ELM, ELX	(83100)	BEFSHCM	(83101)	BEFSGHCM	(83120)	BEFSSIHHCM	139.95
Hasselblad 500C, EL	(83130)	BEFSHC	(83131)	BEFSGHC	(83150)	BEFSSIHHC	126.95
Hasselblad 500CM,ELX,8x10 Format	(83102)	BEFSHCMQ	—	—	(83122)	BEFSSIHCMQ	139.95
Hasselblad 500,EL,8x10 Format	(83131)	BEFSGHC	—	—	(83152)	BEFSSIHHCQ	126.95
Mamiya 645/1000S w/Frame	(83330)	BEFSM645	(83331)	BEFSGM645	(83332)	BEFSSIH645	109.95
Mamiya 645 Super/Pro w/Frame	(83340)	BEFSM645S	(83341)	BEFSGM645S	(83342)	BEFSSIH645P	126.95
Mamiya C330/C330F	(83350)	BEFSMC330	(83351)	BEFSGMC330	(83352)	BEFSSIDMC33Z	109.95
Mamiya C330S	(83360)	BEFSMC330S	(83361)	BEFSGMC330S	(83362)	BEFSSIHMC33Q	109.95
Mamiya RB67/Pro/SD w/Frame	(83310)	BEFSMRB	(83311)	BEFSGMRB	(83312)	BEFSSIHMRB	146.95
Mamiya RZ67 Pro w/Frame	(83320)	BEFSMRZ	(83321)	BEFSGMRZ	(83322)	BEFSSIHMRZ	146.95
Pentax 645	(83610)	BEFSP645	(83611)	BEFSGP645	(83612)	BEFSSIH645	114.95
Pentax 6x7	(83600)	BEFSP67	(83601)	BEFSGP67	(83602)	BEFSSIH67	112.95
Rolleiflex TLR 64x68mm New Style	(83500)	BEFSRTL	(83501)	BEFSGRTL	(83502)	BEFSSIHRTL	119.95
Rolleiflex TLR 56x64mm Old Style	(83520)	BEFSRTLQ	(83521)	BEFSGRTLQ	(83522)	BEFSSIHRTLQ	119.95
Rolleiflex SLX,SL66E,SL6000 Ser	(83510)	BEFSRSL	(83511)	BEFSGRSL	(83512)	BEFSSIHR6	119.95

INTENSSCREEN PLUS FOR	HORIZONTAL SPLIT IMAGE WITH GRID		DIAGONAL SPLIT IMAGE PLAIN		DIAGONAL SPLIT IMAGE WITH GRID		PRICE
	(MFG)	ITEM #	(MFG)	ITEM #	(MFG)	ITEM #	
Bronica ETR/ETRS/ETRSi	(83413)	BEFSSIHGBE	(83414)	BEFSSIDBE	(83415)	BEFSSIDGBE	134.95
Bronica SQ/SQ-A/SQ-Ai/SQ-AM	(83403)	BEFSSIHGBS	(83404)	BEFSSIDBS	(83405)	BEFSSIDGBS	112.95
Bronica GS-1	(83423)	BEFSSIHGBG	(83424)	BEFSSIDBG	(83425)	BEFSSIDGBG	103.95
Fuji GX-680	(83703)	BEFSSIHFGX6	(83704)	BEFSSIDFGX68	(83705)	BEFSSIDFGX6	142.95
Hasselblad 500CM, ELM, ELX	(83121)	BEFSSIHGHCM	(83110)	BEFSSIDHCM	(83111)	BEFSSIDGHCM	139.95
Hasselblad 500C, EL	(83151)	BEFSSIHGHHC	(83140)	BEFSSIDHC	(83141)	BEFSSIDGHHC	126.95
Hasselblad 500CM,ELX,8x10 Format	—	—	(83112)	BEFSSIDHCMQ	—	—	139.95
Hasselblad 500,EL,8x10 Format	—	—	(83142)	BEFSSIDHCQ	—	—	126.95
Mamiya 645/1000S w/Frame	(83333)	BEFSSIHGM645	(83334)	BEFSSIDM645	(83335)	BEFSSIDGM645	109.95
Mamiya 645 Super/Pro w/Frame	(83343)	BEFSSIHGM64Q	(83344)	BEFSSIDM645P	(83345)	BEFSSIDGM64Q	126.95
Mamiya C330/C330F	(83355)	BEFSSIDGMC3Z	(83354)	BEFSSIDMC330	(83355)	BEFSSIDGMC33	109.95
Mamiya C330S	(83363)	BEFSSIHGMC3Q	(83364)	BEFSSIDMC33Q	(83365)	BEFSSIDGMC3Q	109.95
Mamiya RB67/Pro/SD w/Frame	(83313)	BEFSSIHGMRB	(83314)	BEFSSIDMRB	(83315)	BEFSSIDGMRB	146.95
Mamiya RZ67 Pro w/Frame	(83323)	BEFSSIHGMRZ	(83324)	BEFSSIDMRZ	(83325)	BEFSSIDGMRZ	146.95
Pentax 645	(83613)	BEFSSIHGP645	(83614)	BEFSSIDP645	(83615)	BEFSSIDGP645	114.95
Pentax 6x7	(83603)	BEFSSIHGP67	(83604)	BEFSSIDP67	(83605)	BEFSSIDGP67	112.95
Rolleiflex TLR 64x68mm New Style	(83503)	BEFSSIHGRTL	(83504)	BEFSSIDRTL	(83505)	BEFSSIDGRTL	119.95
Rolleiflex TLR 56x64mm Old Style	(83523)	BEFSSIHGRTLQ	(83524)	BEFSSIDRTLQ	(83525)	BEFSSIDGRTLQ	119.95
Rolleiflex SLX,SL66E,SL6000 Ser	(83513)	BEFSSIHGR6	(83514)	BEFSSIDR6	(83515)	BEFSSIDGR6	119.95

Beattie Intenscreens are also available for Mamiya C220. Please Inquire.



# FOCUSING SCREENS

## BEATTIE INTENScreens, *continued*

PRO ACCESSORIES

286

### For 6x9 Field and View Cameras

Beattie 6x9 Intenscreens are available plain or with 1cm grid.

Arca Swiss 6x9 Plain (85031) Item # <b>BEFSAS69</b> ..... <b>174.95</b>	Cambo 6x9 Plain (85041) Item # <b>BEFSC69</b> ..... <b>174.95</b>	Linhof 6x9 Plain (85021) Item # <b>BEFSL69</b> ..... <b>174.95</b>	Mamiya Universal 6x9 Plain (85011) Item # <b>BEFSMU69</b> ..... <b>174.95</b>
Arca Swiss 6x9 Grid (85030) Item # <b>BEFGAS69</b> ..... <b>174.95</b>	Cambo 6x9 Grid (85040) Item # <b>BEFSGC69</b> ..... <b>174.95</b>	Linhof 6x9 Grid (85020) Item # <b>BEFSGL69</b> ..... <b>174.95</b>	Mamiya Universal 6x9 Grid (85010) Item # <b>BEFSGMU69</b> ..... <b>174.95</b>
Toyo 6x9 Plain (85051) Item # <b>BEFST69</b> ..... <b>174.95</b>		Toyo 6x9 Grid (85050) Item # <b>BEFSGT69</b> ..... <b>174.95</b>	

*Intenscreens are also available for more 8x10 and 11x14 cameras on special order. Please inquire.*

## FRESNEL LENSES, GLASS COVER PLATES, SCREENS, FLANGES

### Beattie Fresnel Lenses

Fresnel lens are used for very short wide-angle lenses. They can be installed by either replacing the anti-reflective glass (which is packed with the Intenscreen) with the Fresnel lens, or by taping the Fresnel to the outside cover with heavy photographer's tape. (Sinar users may use an original Sinar Fresnel lens in the holder for this purpose.)

Fresnel Lens for Wide-Angle 4x5 (85998) Please specify camera model. Item # <b>BELF45</b> ..... <b>27.95</b>	Fresnel Lens for Wide-Angle 5x7 (86998) Please specify camera model. Item # <b>BELF57</b> ..... <b>51.95</b>
---	---

Fresnel Lens for Wide-Angle 8x10 (88998)  
Please specify camera model.  
Item # **BELF810**.....**51.95**

### Beattie Glass Cover Plates

A scratch-resistant clear glass exterior cover plate with anti-reflective coating on both sides.

Cover Glass 4x5 (85999)  
Please specify camera model.  
Replacement.  
Item # **BECG45**.....**21.95**

Cover Glass 5x7 (86999)  
Please specify camera model.  
Replacement.  
Item # **BECG57**.....**25.95**

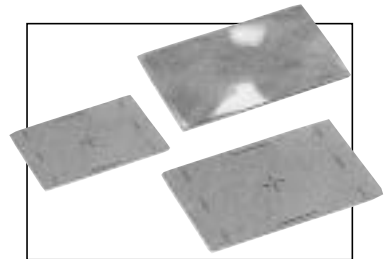

Cover Glass 8x10 (88999)  
Please specify camera model.  
Replacement.  
Item # **BECG810**.....**29.95**

### Bosscreen with Black Grid

For any large format cameras. Retains the in-focus/out-of-focus snap of fine ground glass, but eliminates the grainy texture.

4x5 Bosscreen (1702)  
Please specify camera model.  
Item # **BOFSG45B**.....**156.95**

8x10 Bosscreen (1705)  
Please specify camera model.  
Item # **BOFSG810B**.....**209.95**

### Fresnel Lenses with Black Grid

Fresnel lenses offer a brighter viewing area to judge both camera movements and focusing. The Fresnel can easily be snapped into place over the groundglass.

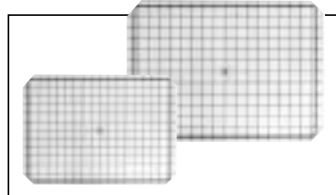

4x5 Fresnel Set (1731)  
Please specify camera model.  
Item # **BRF45**.....**58.95**

8x10 Fresnel Set (1734)  
Please specify camera model.  
Item # **BRF810**.....**128.50**

### Groundglass with Black Grid

4x5 Groundglass (1722)  
Please specify camera model.  
Item # **BRGG45B**.....**33.50**

8x10 Groundglass (1724)  
Please specify camera model.  
Item # **BRGG810**.....**98.95**



### Large Format Lens Flanges

Lens Flange "0" Shutter  
32.5 x 0.5mm thread.  
(Replacement).  
Item # **ROJN32.5**.....**12.50**

Lens Flange "1" Shutter  
39 x 0.75mm thread.  
(Replacement).  
Item # **ROJN39**.....**12.50**

Lens Flange "3" Shutter  
62 x 0.75mm thread.  
(Replacement).  
Item # **ROJN62**.....**22.50**



We are on the web at: <http://www.bhphotovideo.com>

# SHUTTERS/LENSBOARDS

## COPAL SHUTTERS, LENSBOARDS

### Copal Shutters

High performance, durable and large size shutters designed for the professional photographer. Charging the shutter, opening or closing the shutter blades, changing the shutter speeds, changing the aperture stop can be manipulated in any order without the least ill effect on the shutter mechanism. All shutters include rear retaining rings.



Copal #0 Shutter <i>Item # COS0</i> ..... <b>224.95</b>	Copal #1 Press Shutter <i>Item # COPS1</i> ..... <b>248.95</b>
Copal #0 Press Shutter <i>Item # COPS0</i> ..... <b>209.95</b>	Copal #3 Shutter (3585) <i>Item # COS3</i> ..... <b>559.95</b>
Copal #1 Shutter <i>Item # COS1</i> ..... <b>297.95</b>	

### COPAL SHUTTER SPECIFICATIONS

SHUTTER TYPE	#0	PRESS #0 SELF-COCKING	#1	PRESS #1 SELF-COCKING	#3
SHUTTER SPEEDS	1 to 1/500 sec +B and T	1 to 1/125 sec +B	1 to 1/400 sec +B and T	1 to 1/125 sec +B	1 to 1/125 sec +B and T
X-SYNC	✓	✓	✓	✓	✓
MAXIMUM IRIS OPENING	24mm 5-Blade	24mm 5-Blade	30mm 7-Blade	30mm 6-Blade	45mm 7-Blade
LENS MOUNTING FRONT	29.5mm	29.5mm	40mm	40mm	56mm
LENS MOUNTING REAR	29.5mm	29.5mm	35mm	36mm	56mm
OUTER DIAMETER	61mm	63mm	73mm	73mm	102mm
WEIGHT	4oz (115g)	3.5oz (100g)	5.6oz (160g)	4oz (115g)	12oz (340g)

*Subject to change without notice*

### METAL LENSBOARDS

Metal flat lensboards are available for a number of cameras, undrilled or predrilled for copal shutter sizes, ready to use. Shuttered lens will attach by locking retaining ring onto board.

#### 96x99 Technika/Wista Type Lensboards

Blank Lensboard, Undrilled <i>Item # GBLBBLT</i> ..... <b>38.95</b>	#1 Lensboard (1401) <i>Item # GBLB1LT</i> ..... <b>38.95</b>
#0 Lensboard (1400) <i>Item # GBLBOLT</i> ..... <b>38.95</b>	#3 Lensboard (1403) <i>Item # GBLB3LT</i> ..... <b>38.95</b>
#0 Recessed Lensboard (1408) <i>Item # BRLBROLT</i> ..... <b>122.50</b>	

#### Graphic Type Lensboards

Blank Lensboard, Undrilled (1469) <i>Item # GBLBBG</i> ..... <b>28.95</b>	#1 Lensboard (1461) <i>Item # GBLB1G</i> ..... <b>38.95</b>
#0 Lensboard (1460) <i>Item # GBLB0G</i> ..... <b>38.95</b>	#3 Lensboard (1463) <i>Item # GBLB3G</i> ..... <b>38.95</b>
Blank Lensboard (Undrilled) for 2¼x 3¼ Models (1468) <i>Item # GBLBB69G</i> ..... <b>28.95</b>	

#### 139x139 Sinar/Horseman View Type Lensboards

Blank Lensboard, Undrilled (1439) <i>Item # GBLBBS</i> ..... <b>47.95</b>	#1 Lensboard (1431) <i>Item # GBLB1S</i> ..... <b>49.90</b>
#0 Lensboard (1430) <i>Item # GBLB0S</i> ..... <b>49.90</b>	#3 Lensboard (1433) <i>Item # GBLB3S</i> ..... <b>49.90</b>

#### 110x110 Toyo Field Type Lensboards

Blank Lensboard, Undrilled (1459) <i>Item # GBLBBTF</i> ..... <b>48.95</b>	#1 Lensboard (1451) <i>Item # GBLB1TF</i> ..... <b>48.95</b>
#0 Lensboard (1450) <i>Item # GBLB0TF</i> ..... <b>48.95</b>	#3 Lensboard (1453) <i>Item # GBLB3TF</i> ..... <b>48.95</b>

#### 158x158 Toyo View Type Lensboards

Blank Lensboard, Undrilled (1449) <i>Item # GBLBBTV</i> ..... <b>39.95</b>	#0 Lensboard (1440) <i>Item # GBLB0TV</i> ..... <b>39.95</b>	#1 Lensboard (1441) <i>Item # GBLB1TV</i> ..... <b>29.95</b>	#3 Lensboard (1443) <i>Item # GBLB3TV</i> ..... <b>39.95</b>
---	---	---	---



# EXTENDERS/VIEWERS

H O R S E M A N , K E N K O , T I F F E N , P E A K

PRO ACCESSORIES  
288

## Large Format Teleconverter

**Horseman 2x LF Teleconverter 150-300 (25231)**  
For large-format lenses. Enables you to convert most 150mm focal distance lenses up to 300mm. The 7-element, 5-group construction uses extra-dispersion glass so as not to effect the sharpness, color balance or image circle of the original lens. The exposure factor is two f-stops. Mounting and unmounting is easily achieved. Its compact size makes it perfect for on-location shooting.  
**Item # HOTCLF.....464.95**

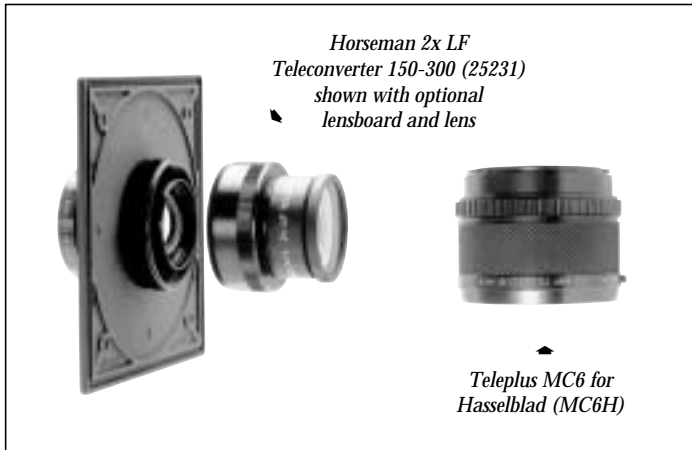

## Teleconverters for Medium Format Cameras

KENKO Teleplus MC6 is a multi-coated converter, precision engineered to the highest technical specifications, well comparable with those of high-priced lenses. Fully automatic coupling with the camera's mechanism. Exposure factor is 2 stops.

**Teleplus MC6  
for Hasselblad (MC6H)**  
**Item # KE2XH.....279.00**

**Teleplus MC6  
for Mamiya M645 (MC6M645)**  
**Item # KE2XM645 .....259.95**

**Teleplus MC6  
for Mamiya RB67 (MC6M67RB)**  
**Item # KE2XMRB.....399.00**

**Teleplus MC6  
for Pentax 6x7 (MC6P67)**  
**Item # KE2XP67 .....414.95**

## Tiffen Contrast Viewing Filters

Balancing lighting by eye is a matter of experience. Decisions can be aided through the use of contrast viewing filters. These are designed to handicap the eye, with its much greater range of apparent densities, to resemble the range of the various types of film. Use contrast viewers to judge relative highlight and shadow densities. There are viewers for black-and-white film, as well as various viewer densities for color film. A darker viewer is used for a slower film speeds, where you would tend to use brighter lighting. Faster film, which can be used in dimmer settings, would require a lighter viewer.

**#1 Black & White  
Viewing Filter 90-50**  
For black and white imaging.  
**Item # TIVF1.....29.50**



**#2 Color Viewing  
ND 2.0 Filter**  
For film speeds to 100. Can  
also be used for video.  
**Item # TIVF2.....29.50**

**#3 Color Viewing Filter  
for Fast Film**  
For faster films. Best suited for  
lower light levels. Can also be  
used for video.  
**Item # TIVF3.....29.50**

**#4 Process Viewing Filter  
Green Glass**  
For process photography.  
**Item # TIVF4.....29.50**

**#5 Blue Screen Viewing Filter**  
For blue screen work, as well as  
for setting up color video moni-  
tors.  
**Item # TIVF5.....29.50**

## Peak Viewing Filters

Renders tonal values as they will be reproduced by the film. Preview shadows and highlights. Folds into case. Supplied with eyelet for neck strap.

**Viewing Filter PV1F  
for Black & White (1967M)**  
**Item # PE1967M.....49.95**



**Viewing Filter TC1F  
for Color (1967C)**  
**Item # PE1967C.....49.95**

*Viewing  
Filter PV1F  
for Black & White (1967M)*

## KENKO TELEPLUS SPECIFICATIONS

	HASSELBLAD	MAMIYA RB	MAMIYA 645	PENTAX 67
WEIGHT:	12.5oz (355g)	21.5oz (610g)	9.2oz (260g)	19.9oz (565g)
LENGTH:	2.6" (67mm)	3.6" (92mm)	2" (53mm)	3" (77mm)
MAGNIFICATION:	2x	2x	2x	2x
DEPTH-OF-FIELD:	1/2 of Prime Lens	1/2 of Prime Lens	1/2 of Prime Lens	1/2 of Prime Lens
MINIMUM FOCUSING DISTANCE:	Same as Prime Lens	Same as Prime Lens	Same as Prime Lens	Same as Prime Lens
LENS CONSTRUCTION:	6 Elements in 5 Groups	6 Elements in 5 Groups	6 Elements in 5 Groups	6 Elements in 5 Groups
EXPOSURE COMPENSATION:	2 stops	2 stops	2 stops	2 stops

**Most Orders Shipped Within 24 Hours**

# 2-WAY RADIOS

MOTOROLA / KENWOOD

## Motorola Spirit Radios

Motorola Spirits are durable lightweight clear dependable communications designed for short range wireless solutions. They all come with a private line feature to eliminate unwanted conversations from other nearby users. Select models offer extra features such as multiple channels, scanning capability and built-in hands free operation. Range for 1 and 2 watt VHF models is up to 160,000 sq. ft. or 10 floors in and around structures or 2-4 miles in open flat areas with few obstructions. Range for 1 & 2 watt UHF models is up to 250,000 sq. ft. or 20 floors in and around structures or 6 miles in open flat areas with few obstructions. High power models (MV52CST & SU42CST) offer increased range over the 1 and 2 watt models by up to 20%. Spirit 1 & 2 watt models are shadow bronze in color, Spirit high power models are light gray in color. All Spirit radios and accessories are backed by Motorola's authorized One-Year Over The Counter Exchange Warranty. All Spirit radios come complete with standard antenna, rechargeable Ni-Cd battery, belt clip, wall charger or desktop charger depending on model, user manual and warranty card.



Spirit Radio

### VHF RADIOS

	Watt	Channel	Voice Activated	Scan	Charger	Item #	Price Each
MV11C	1	1	NO	NO	WALL	MOMV11C	198.95
MV21CV	2	1	YES	NO	WALL	MOMV21CV	219.95
MV22CV	2	2	YES	NO	WALL	MOMV22CV	249.95
MV22CVS	2	2	YES	YES	WALL	MOMV22CVS	279.95
MV24CVST	2	4	YES	YES	DESKTOP	MOMV24CVST	299.95
MV52CST	5	2	NO	YES	DESKTOP	MOMV52CST	389.95

### UHF RADIOS

	Watt	Channel	Voice Activated	Scan	Charger	Item #	Price Each
MU21CV	2	1	YES	NO	WALL	MOMU21CV	249.95
MU22CV	2	2	YES	NO	WALL	MOMU22CV	269.95
MU22CVS	2	2	YES	YES	WALL	MOMU22CVS	289.95
MU24CVST	2	4	YES	YES	DESKTOP	MOMU24CVST	319.95
SU42CST	4	2	NO	NO	DESKTOP	MOSU42CST	399.95

## Spirit Accessories

- Replacement Nicad Battery** (HNN9056)  
**Item # MOHNN9056.....34.95**
- 10-hour Desktop Charging Tray** (HNN9204)  
**Item # MOHNN9204.....24.95**
- 3-Hour Quick Charger** (HNN9205)  
**Item # MOHNN9205.....54.95**
- Hand-Held Speaker Microphone** (HMN9026)  
**Item # MOHNN9026.....59.95**
- Headset with Swivel Boom Mic** (HMN9038)  
**Item # MOHNN9038.....59.95**
- Earpiece with Microphone** (HMN9039)  
**Item # MOHNN9039.....54.95**
- Leather Case** (MR6046)  
**Item # MOMR6046.....29.95**

## Kenwood Freetalk

- FreeTalk Personal Radio** (UBZLF14B)  
 Chic, lightweight and tough, Kenwood's FreeTalk is ideal for staying in touch with family and friends. Because it's an FRS (Family Radio Service) transceiver, you don't need a license. Yet it has a maximum range of 2 miles. It costs nothing to use, and can operate for up to 38 hours. With the unique PrivacyTalk feature, you can talk anywhere—out in the countryside or in a crowded mall—without fear of eavesdropping. And FreeTalk has 14 channels and 38 talk groups—when combined with PrivacyTalk that gives you 1064 ways to communicate!  
 Requires 3 AA alkaline batteries.  
 Dimensions: 2.2 x 4.0 x 1.0" (WxHxD).  
 Weighs 6.3 oz. (including 3 AA batteries and belt clip).  
**Item # KEUBZLF14B.....149.95**



FreeTalk Personal Radio (UBZLF14B)

- Speaker Microphone** (SMC-34)  
 Enables auto channel select as well as 3-key remote control and volume control of your FreeTalk transceiver. Swivel clip. Splash-proofing.  
**Item # KESMC34.....39.95**
- Headset** (HMC-3)  
 For hands-free use of the FreeTalk, which you can strap to your belt. Choice of VOX mode for voice-activated TX/RX (transmit/receive) and PTT mode for manual switching between transmit & receive.  
**Item # KEHMC3.....54.95**
- Clip Microphone** (EMC-3)  
 Clips to a shirt or jacket collar. Supplied with an earphone for clear reception  
**Item # KEEMC3.....29.95**



# LADDERS

## PRO-STEP

*For the photographer or videographer who still struggles with a heavy, unstable and unsightly carpenter-style ladder, the Pro-Step line of ladders will help you look and feel like a professional.*

*Made of feather-weight aluminum and seamless tubular construction, the Pro-Step is both easy to carry and full of sturdy support. While reinforced treads and locking platform provide extra stability - even on the top step - Pro-Step's anti-slip footings and full length support bar insure balance and safety.*

*The Pro-Step features front mounted, velcro fastened signboard, into which fits a letter-size sheet of paper that can include a company logo and congratulatory message, protected edges which guard against scratches and support bar for "rock steady" stability on platform.*



*When you absolutely need the height, Pro-Step gives you the confidence.*

3-Step Aluminum Ladder  
Item # PRL3SA.....**149.00**

3-Step Black Ladder  
Item # PRL3SB.....**169.00**

4-Step Aluminum Ladder  
Item # PRL4SA.....**159.00**

4-Step Black Ladder  
Item # PRL4SB.....**179.00**

5-Step Aluminum Ladder  
Item # PRL5SA.....**179.00**

5-Step Black Ladder  
Item # PRL5SB.....**199.00**

6-Step Aluminum Ladder  
Item # PRL6SA.....**203.95**

6-Step Black Ladder  
Item # PRL6SB.....**224.00**

### Pro-Pouch

Never lose an accessory again! The Pro-Pouch slips onto any Pro Step ladder. Made of indestructible Cordura, the Pro-Pouch has three front pouches for holding lenses and two side pouches for batteries, tapes and accessories.

Item # PRPP1 .....**49.95**



### PRO-STEP SPECIFICATIONS

Model	3-STEP	4-STEP	5-STEP	6-STEP
Maximum Weight Capacity	325 lbs. (147kg)	325 lbs. (147kg)	325 lbs. (147kg)	325 lbs. (147kg)
Platform Height	27" (66cm)	36" (91cm)	44" (112cm)	53" (135cm)
Weight	5 lbs. (2.3kg)	6 lbs. (2.7kg)	8 lbs. (3.6kg)	9 lbs. (4kg)
Width at Bottom	16½" (42cm)	17½" (44cm)	19" (48cm)	20" (50cm)
Depth at Bottom (Open)	26" (66cm)	31½" (80cm)	39" (99cm)	45" (114cm)
Folded Dimensions H.W.D.	52 x 16.5 x 4.5" (132 x 42 x 11cm)	61 x 17.5 x 4.5" (155 x 44 x 11cm)	69 x 19 x 4.5" (175 x 48 x 11cm)	78 x 20 x 4.5" (198 x 51 x 11cm)

*Subject to change without notice*

**We Exhibit at National and Regional Shows/Conventions**