



The Professional Lighting

for Photo, Video, Cine & Theatrical

SourceBook

Section 5

Strobe Lighting - AC Strobes-Slaves-Cords

SP Studio Systems	208-211
Morris	212
Pocket Wizard	213-214
Quantum	215-216
Wein	217-219
Paramount	220-221

LANCER LIGHT SERIES AC/DC STROBES

A versatile new line of AC/DC strobes that are suitable for use in portrait or product photography, either in the studio or on location. Also ideal for conventional and digital photography. Powered by AC or an optional portable DC battery pack. This makes the entire series the perfect lights on location. All Lancerlight AC/DC lights are compatible with Quantum Turbo and Lumedyne High Voltage Cyclor Battery Packs.

SPC-100 AC-DC (SPC100ACDC)

- Flash Output: 70w/s
- Front and rear Ready Light
- Power Source: AC 100-120V, 60 Hz or DC Battery Pack
- Recycle time:
 - AC- 3-5 sec.
 - DC-Fast 2.5 sec.
 - DC-Ultra Fast 2 sec.
- Number of Shots (DC only) 450 avg. per charge
- Flash Duration: 1/400 sec.
- Slave Sensor: Yes
- Color Temperature: 5200°K
- Dimensions: 5x4¼" (13x11cm)
- Weight: 14 oz. (370g)
- Accessories included: PC Synchro-cord, AC power cord and DC power cord

Item # SPACDC100.....119.95

SPC-147 AC-DC (SPC147ACDC)

- Flash Output: 100w/s
- Front and rear Ready Light
- Adjustable power: Full, half, or quarter by switch
- Power Source: AC 100-120V, 50/60 Hz or optional DC Battery Pack
- Recycle time:
 - AC-Full 4-6 sec.
 - DC-Fast 3 sec.
 - DC-Ultra Fast 2 sec.
- Number of Shots (DC only) 425 avg. per charge
- Slave Sensor: Yes
- Color Temperature: 5200°K
- Dimensions: 5x4¼" (13x11cm)
- Weight: 1 lb. (0.5kg)
- Accessories included: PC Synchro-cord, AC power cord, DC power cord

Item # SPACDC147.....139.95

SPC-920 AC-DC (SPC920ACDC)

- Flash Output: 100w/s
- Modeling Lamp: 60W
- Top Ready Light
- Adjustable power: Full, 1/2, 1/4
- Power Source: AC 100-120V, 50/60 Hz or DC Battery
- Recycle time: AC-Full 4-6 sec. DC-Fast 3 sec. DC-Ultra Fast 2 sec.
- Number of Shots (DC only) 450 avg. per charge
- Slave Sensor: Yes
- Color Temperature: 5200°K
- Dimensions: 4¼x6¼" (10x17cm)
- Weight: 1.5 lbs. (0.7kg)
- Accessories included: PC Synchro-cord, AC power cord, DC power cord

Item # SPACDC920.....159.95

Background Image Projector Attachment (SPBIP)

Fits on SP920, 147 and model 100 strobes. Focusing fresnel lens. Uses Rosco Pattern inserts, not included.

Item # SPIP.....39.95



DC Power Battery Pack (SPDCBP)

Works with SPC1600ACDC, SPC920ACDC, SPC147ACDC, and SPC100ACDC. Also works with most flashes that use Quantum Turbo and Lumedyne MiniCyclor battery packs.

- Rechargeable: by the 18V 600mA AC/DC adapter (included)
- Output - approximately DC 305V, 50mA
- Battery Capacity - DC12V, 2.3Ah
- Battery Type - Sealed Lead Acid
- Weight - 3lbs (1.4kg)

Approximate Flashes at Full Power

- 270ws = 110 Flashes
- 100ws = 320 Flashes
- 160ws = 190 Flashes
- 70ws = 380 Flashes

Item # SPDC12PP.....123.95

LANCER LIGHT SERIES AC/DC KIT



Lancer Light Portrait Kit (SPLLPK)

Great for on location portrait-ture, and any other shooting situation that requires 3 lights.

Consists of:

- (2) 920 AC/DC lights
- (1) 100 AC/DC light
- (2) BKR920 brackets
- (1) SP Bracket
- (1) SP Snoot
- (2) 33" White Umbrellas
- (2) 8" Aluminum stands
- (1) 3' Backlight stand
- (1) Barndoor set
- (1) Sp-Bag.

Item # SPLLPK.....679.95

AC STROBES

SP-S100 Strobe (SPS100)

The versatile SP-S100 is the foundation of the line and remains an outstanding value for a compact and powerful flash that's easy to use. Simply screw this little powerhouse into a standard lamp socket. Trigger it with the supplied PC cord attached to your camera, or remotely activate the SP-S100 with its sensitive built-in slave trigger. Even cumulative flash exposures are possible with the manual flash button. Accessories and unique controls tailor the system to your photography without emptying your pockets.

Item # SPS100 64.90

SP-147VP AC Strobe with Variable Power (SP147VP)

When the situation calls for more power, the SP-147VP delivers twice the power of the SP-100. Variable power output with settings of full, half and quarter power output permits fine tuning of lighting ratios and depth of field. Utilizing the same versatile accessories as the SP-100 and SP-920MDLVP, the SP-147VP offers the option of providing efficient lighting modification.

Item # SP147 99.95

Bare Bulb Strobe (SPBULB2)

Super wide angle 180° coverage. Guide number 40 w/100ASA. Built in ultra sensitive slave.

Item # SPBB2 34.95

SP-S920 Strobe with Modeling Light (SPS920)

The SP-S920 is the backbone of the SP Studio System with its built-in high intensity 60W modeling light that provides the visual preview needed for precise results. Creative light ratio and depth of field control are now easier than ever, with the addition of variable power control (Full, 1/2, and 1/4 power settings). Shadow control and hot spots no longer stand in the way of your photographic creativity.

Item # SPS920 114.95

SP-72 AC Slave Strobe (SP72)

The SP-72 is a workhorse that boosts or fills in with any electronic flash by means of its built-in slave. Fits a crowded camera bag on the road and takes on any number of chores in the studio. The SP-72 is also a perfect light source for copy stands.

Item # SP72 32.50

SP-72PCT Master AC Slave Strobe (SP72PCT)

Same features as Model 72, has PC socket that allows low voltage triggering directly from a camera sync terminal. PC cord is included as well as test button.

Item # SP72PCT 49.95



SP-150 AC Strobe (SP150)

The four-tube SP-150 delivers as much flash output as lights with nearly 30% higher ratings. A switchable 60W modeling light guides visualization. Variable power flash control adjusts the flash output from full, 1/2, 1/4, 1/8, to 1/16th levels. Recycling time is under five seconds.

Item # SP150 179.95



SOFTBOXES

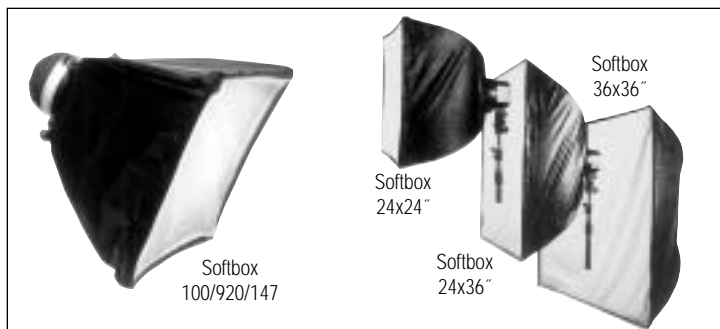

10" x 10" (25x25cm) (SPSOFT) for SP100/920/147.

Item # SPSB1010100 49.95

24" x 36" (61x91cm) (SPSOFT150) for SP150/250.

Item # SPSB2436150 94.95

Item # SPSB2436250 94.95

36" x 36" (91x91cm) for SP150 and SP250 (SPSOFT1503)

Item # SPSB3636150 104.95

Item # SPSB3636250 104.95

24" x 24" (61x61cm) (SPSOFT2) for SP100/920/147.

Item # SPSB2424100 69.95

24" x 24" (61x61cm) (SPSOFT1502) for SP150/250.

Item # SPSB2424150 79.95

Item # SPSB2424250 79.95

AC KITS



Mini Portrait Kit (SPMPKIT)
 Consists of;
 (1) SP-72 Strobe
 (1) SP-72PCT Strobe
 (1) SP-BARN72 Barndoors
 (2) SP-CLAMP AC socket & clamp set
 (1) SP-FILT72 Colored filter set
Item # SPMPK.....86.95

Starter Kit (SPSTARTKS)
 Consists of;
 (1) SP-S920 Strobe
 (1) SP-S100 Strobe
 (1) SP-BRK920 Swivel bracket
 (1) SP-HOLD AC socket & cord
 (1) SP-CLAMP AC socket & clamp
 (1) RSTAND 72" (183cm) stand
 (1) 33" Umbrella
Item # SPSK249.95

Pro Starter Kit (SPPROS)
 Consists of;
 (1) SP-150 Strobe
 (1) SP-HDS8 96" lightstand
 (1) SP-BRACK Swivel bracket
 (1) SP-Soft1503 3' x 3' softbox
Item # SPPSK289.95

Home Studio Kit (SPKITS)
 Consists of;
 (2) SP-S100 Strobes
 (1) SP-72 Strobe
 (1) SP-SOFT Softbox attachment
 (1) SP-BARN100 Barndoors
 (2) SP-BRACK Swivel brackets
 (1) SP-CLAMP AC socket and clamp set
 (1) 33" White Umbrella
 (2) 96" (244cm) lightstands
 (1) Corrugated foam lined case with handle.
Item # SPHSK384.95

Home Studio Kit (SPKITRS)
 Same as above, with
 (2) 72" (183cm) lightstands
Item # SPHSRK.....377.50

Home Studio Kit (SPKITBS)
 Same as above, with
 (2) 96" (244cm) lightstands
 (1) SP-BAG
Item # SPHSSPK.....434.95

Portrait Kit (SPPORTKS)
 Consists of;
 (2) SP-S920 Strobes
 (1) SP-S100 Strobe
 (1) SP-SNOOT for SP-100
 (2) SP-HOLD AC socket & cord
 (1) SP-CLAMP AC socket and clamp
 (2) SP-BRK920 Swivel brackets
 (2) 96" lightstands
 (1) SP-BARN100 Barndoors
 (2) 33" White umbrellas
 (1) Corrugated foam lined case with handle
Item # SPHPK.....429.505

Portrait Kit (SPPORTKRS)
 with 72" lightstands.
Item # SPPRK449.95

Portrait Kit (SPPORTKBS)
 with 96" lightstands & SP-BAG
Item # SPHPSPK.....456.95

Portrait Kit (SPPORTKRBS)
 with 72" (183cm) lightstands
Item # SPPRSPK.....504.95

Commercial Kit (SPCOMKS)
 Consists of;
 (2) SP-150 Strobes
 (1) SP-BARN150 Barndoors
 (1) SP-S100 Strobe
 (1) SP-SNOOT
 (1) SP-UMB40W 40" white umbrella
 (2) SP-BRACK Swivel brackets
 (1) SP-CLAMP AC socket & clamp
 (2) 96" lightstands
 (1) Corrugated foam lined case with handle.
Item # SPCK.....589.95

Commercial Kit (SPCOMKB)
 Same as above, with SP-BAG.
Item # SPCSPK639.95

LIGHTING Q&A

Who owns the rights to the pictures—me or the client?

You do. Legally, the photographer owns his own negatives.

Copy excerpted with permission of Amphoto Books © 1995 by John Hart 50 Portrait Lighting Techniques.

SP Studio Systems AC Kits

ACCESSORIES



Snoot (SPSNOOT)
for hair lights/147VP/SP-100.
Item # SPS **12.95**

Snoot (SPSNOOT920)
for 920 AC Strobe.
Item # SPS920Q **24.95**

Conical Snoot with Medium Honeycomb (SPCON)
Item SPSC..... **39.95**

4-Leaf Barndoor (SPBARN100)
for SP-100 series.
Item # SPBD920..... **24.95**

Barndoor (SPBARN72)
for SP-72.
Item # SPBD72..... **9.95**

Barndoor (SPBARN150)
for SP150/250.
Item # SPBD150..... **39.95**

Filter Set (4) (SPFILT72)
for SP-72.
Item # SPFS72 **8.95**

Socket & Spring Clamp (SPWSCL)
Item # SPSSCS..... **9.95**

Porcelain Socket/Rubber Coated Clamp (SPCLAMP)
Item # SPCS..... **11.95**

Light Holder (SPHOLD)
with In Line Switch.
Item # SPLH..... **19.50**

Swivel Bracket (SPBRK920)
for SP-S920.
Item # SPBQ..... **18.95**

Swivel Bracket (SPBRACK)
for Umbrella/Lights.
Item # SPB..... **13.95**

Modeling Lamp (SP920VPB)
for 920MDL-VP/SP250.
Item # SPML920VP **15.95**

Modeling Bulb
for old 920MDL.
Item # SPML920MDL..... **5.49**

PC-Sync Cord (SP100PC)
for SP-100/920VP/147VP.
Item # SPSC147..... **9.95**

PC-Sync Cord f/SP-150 (SP150PC)
Item # SPSC150..... **9.95**

PC-Sync Cord (SP250PC)
for SP-250 and old models of 920MDLVP.
Item # SPSC250..... **9.95**

Power Cord f/SP-150 (SP150AC)
Item # SPACA150 **19.95**

SP STUDIO SYSTEMS

SLAVES

SLAVES

Bare Bulb Slave Unit (SPMBB)
Has an "angle cut" case design which allows it to be positioned at any angle. Number of flashes: 300 (w/fresh batteries). Recycling time: 4 seconds. GN: 20' /ISO 100. Dimensions 2.5x2 1/2" (6.3x6.7cm)
Item # SPMBBS **22.95**

Mini Slave (SPMINI)
Has a "diamond cut" case design which allows it to be positioned at any angle.
Number of flashes: 260 (w/fresh batteries)
Recycling time: 8 seconds
GN: 50' /ISO 100
GN: 30' /ISO 100 (with diffuser in position)
Dimensions 2.5x2 1/2"x1 1/2" (6.3x6.7x4.1cm)
Item # SPMS..... **24.95**

Midi Slave Flash (SPMIDI)
Extra power for fill light, side light or background light. GN# 45 with ISO 100 film. 50° angle of coverage. Recycles in 4 seconds with fresh batteries.
Features built in slave trigger. Hot shoe for on camera use. Swing away bracket for low angle adjustments. Built in 1/4x20 mount for use on light stands, tripods and brackets.
Item # SPM..... **24.95**



AC SLAVES

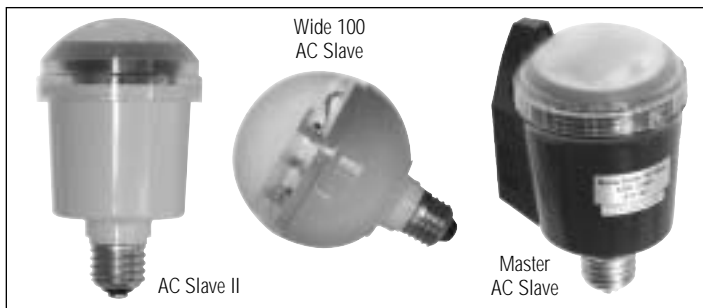

AC Slave II (11140)

The Morris AC Slave II expands your capabilities without sync cables. It is an excellent complement to the Master AC Slave. Green and red LEDs are mounted under the dome to indicate AC power and recycle status. A test button is provided. This being most popular flash unit, the AC Slave II is triggered by a reliable built-in slave. It fits any standard 110V AC lamp base socket. The guide number is 66 with ISO 100 film. It recycles in 4 seconds.

Features

- 21 W/s of power
 - GN 66 (ISO 100, ft.) 50° flash coverage
 - Open flash button
 - Green power on lamp, red ready lamp.
- Item #MOACSS2.....34.95**

AC Super Slave (11150)

Hammering out the highest power of all 5 Morris AC Slaves, this unit offers a guide number of 72 with ISO 100 film. You can throw light further or operate at higher f-stops. Like all the Morris AC's, a reliable slave senses the light of the main flash and instantly fires the Super Slave. With 70° of coverage, the Super Slave can be used as a main light, a supplementary fill light or even as a background light. Recycles in 5 seconds.

Features

- 30 W/s of power
 - GN 72 (ISO 100, ft.) 70° flash coverage
 - Open flash button
 - Green power on lamp, red ready lamp.
- Item # MOACSS.....49.95**

Master AC Slave (11145)

A coiled 4 foot removable sync cable and built-in slave let this unit function as either a main or slave light. One Master AC Slave and 1 or 3 AC Slave II's are perfect for copystand use! With 50° of coverage, the Master AC Slave has a guide number of 66 with ISO 100 film and recycles in 4 seconds. When used as the master flash, it requires an optional 6 volt PX28 or 544 battery.

Features

- 25 W/s of power
 - GN 66 (ISO 100, ft.) 50° flash coverage
 - Open flash button
 - Ideal for copy stands
 - Uses 1 PX28 6V battery (not incl.)
- Item # MOMACS.....38.95**

Wide 100 AC Slave (11155)

As its name implies, the Wide 100 AC Slave provides 100° coverage and is an excellent unit for direct lighting when using wide angle lenses or for broad and soft coverage. When you want to concentrate power from a single direction, use multiple Wide 100 AC's to boost the f-stop. Like the other Morris AC Slaves, it is triggered by your main flash unit through a built-in slave sensor. The lamp base fits any standard 110V light socket. The Wide 100 has a guide number of 36 with ISO 100 film and recycles in 5 seconds.

Features

- 32 w/s of power
 - GN 36 (ISO 100, in ft.) 100° flash coverage
 - Open flash button
 - Green power on lamp, red ready lamp
- Item #MOW100ACS.....44.95**

DC SLAVES

Mini Slave Flash II with PC Cord (11770)

Usage Options:
Groups/Accent/Backgrounds.

Features

- Compact & powerful
- Triggered by your camera or another flash
- 1/4-20 socket (tripod mount)
- Wrist strap
- 1.25" x 2.4" x 2.5"
- Can be used with the New! Suction Cup!

Specifications

- Power Source: 2 AA size batteries
 - Guide Number: 36 (ISO 100 in feet)
 - 28 with diffuser (ISO 100 in feet)
 - Subject Distance: 1.5 - 16.5 feet
 - Angle of Coverage: 65x50°, 80x65° (w/adaptor)
 - Recycling Time: 6 seconds
- Item #MOMS2.....31.95**

Mini Slave Flash Plus (11174)

Usage Options:
On the Camera/Groups/Accent/Backgrounds.

Features:

- Compact & powerful
- Triggered by your camera or another flash
- PC-PC sync cord
- Slaveless cap at strobe use
- 2.25 x 2.25 x .875" (not including hot shoe)

Specifications

- Power Source: 1 AA size battery
 - Guide Number: Hi 10 (ISO 100m)
 - Low 5.6 (w/detachable wide adaptor)
 - Subject Distance: Hi 0.5-5.0m (ISO 100m)
 - Angle of Coverage: Hi 50 x 65, Lo 65 x 80
 - Recycling Time: 6 seconds
- Item # MOMSP.....39.95**

Mini Slave Wide Plus with PC Cord (11173)

Usage Options:
Groups/Accent/Backgrounds.

Features

- Compact, easy to carry & conceal
- Triggered by your camera's flash
- Eliminate unwanted shadows
- Domed Cylinder 2.6 x 2.3"

Specifications

- Power Source: 2 AA size batteries
 - Guide Number: 24 (ISO 100 in ft.)
 - Subject Distance: 1.5 - 10 feet
 - Angle of Coverage: 120°
 - Recycling Time: 4 seconds
- Item # MOMSWP.....31.95**

Midi Slave (White) (11270)

Usage Options:
Groups/Accent/Backgrounds.

Features:

- Compact & powerful
- Triggered by your camera or another flash
- 1/4-20 socket (tripod mount)
- wrist strap
- 1.2 x 2.4 x 2.5"
- Can be used with the New! Suction Cup!

Specifications

- Power Source: 2 AA size batteries
 - Guide Number: 56 (ISO 100 in feet)
 - Angle of Coverage: 65x50° 80x65° (w/adaptor)
 - Recycling Time: 5 seconds
- Item # MOMSW.....36.95**

Midi Slave (Black) (11275)

Same as above only in Black.

Item # MOMSB.....36.95

Maxislave (11375)

Usage Options:
On the Camera/Groups/Accent/Backgrounds.

Features

- Compact w/hotshoe mount & PC cord
- Hi-Low power
- Triggered by your camera's flash
- Detachable wide angle adapter
- Slave/Sync selector
- Ready light
- Test Button
- 3" x 3" x 1.25" (not including hotshoe)
- Can be used with the New Suction Cup!

Specifications

- Power Source: 4 AA size batteries
 - Guide Number (ISO 100 in feet): Hi: 80/24 (40/12 w/adaptor)
 - Lo: 56/17 (28/8.5 w/adaptor)
 - Effective Distance (ISO 100 FILM): Hi: 1.6-33 ft. (1.6-17 ft. w/adaptor)
 - Lo: 1.6-23 ft. (1.6-12 ft. w/adaptor)
 - Angle of Coverage: 70° vertical (90°w/adaptor)
 - 60° horiz. (80° w/adaptor)
 - Number of Flashes: 400
 - Recycling Time: 4 seconds
- Item # MOMSBQ.....49.00**

Maxislave (11376)

Same as above in white.

Item # MOMSWQ.....49.00

Morris Slaves

POCKET WIZARD PLUS



The Pocket Wizard Plus is the result of 10 years of experience building sophisticated remote triggering tools for photographers. The Plus uses the most advanced digital radio system in the photographic industry, to deliver impressive range and reliability for the professional photographer. Sixteen bit digitally coded radio signals means the receiver cannot be triggered or "locked up" by other radio noise. Microprocessor control guarantees consistent sync speeds under even the worst conditions.

The Plus is built around a new streamlined case with a hot shoe mount on the transmitter and a shoe mount on the receiver. Each unit has a 1/4-20 threaded mount for use with a bracket/clamp, and the hanging lanyard included with the kit makes mounting a remote receiver on a stand a snap. The captive battery door means you can never lose it while changing batteries and juggling ten other tasks simultaneously as photographers need to do. The two AA batteries can be changed quickly, and the new 200-250 hour battery life will carry you through many jobs worry-free. Four digitally coded channels provide reliable triggering for up to four photographers in the busiest reception halls.

Pocket Wizard Plus Transmitter and Receiver (801101)

Item # WIPWPK **335.00**

Pocket Wizard Plus Transmitter (801102)

Item # WIPWPT **165.00**

Pocket Wizard Plus Receiver (801103)

Item # WIPWPR **184.00**

POCKET WIZARD MULTIMAX

The new PocketWizard MultiMAX Transceiver is the most innovative and advanced Digital Radio Slave with integrated "Trigger Time Control" software, True Trigger Confirmation and "Selective Quad Triggering". The MultiMAX features next generation "Wireless Transceiver Technology" which eliminates the need for separate transmitter/receiver triggering configuration. Each MultiMAX provides the capability to send and receive digital signaling by a flip of a switch, similar to personal communicators. Among many advantages, a photographer can select between a transmitter or a receiver as shooting assignments change. Through its use of advanced transceiver technology, the MultiMAX offers the only true triggering confirmation feedback up to 1600 feet away, without the need for signal repeaters or daisy-chained radios. In the "Selective Quad Triggering Mode", the MultiMAX automatically confirms (on the selected transmitter) every zone simultaneously, with immediate visual and audible feedback. Using the optional Flash Confirmation Cable, the transmitter receives a visual and audible signal, confirming that a triggered flash actually fires. Finally, there's a real confirmation system which reassures the photographer that everything is working from the camera position. Utilizing the full potential of LPA Design's patented microprocessor and software technology, the MultiMAX comes loaded with "Triggering Time Control" software. This software package offers several tools for the working professional all in one small package. With the "Triggering Time Control" software, it's easy and very convenient to create rear-curtain sync effects with any camera, add depth of field using multipop mode and record events as they unfold using the intervalometer mode.



-Plus-

As with all PocketWizard Digital Radio Receivers, the MultiMAX is fully compatible with Sekonic's new L-608 and L-358 exposure meters configured with the plug-in digital radio transmitter module. Now you can trigger electronic flash units and/or cameras with your Sekonic L-608 or L-358 meter and PocketWizard Digital Radio Receivers.

Display

Liquid Crystal (LCD) panel with backlight illumination button
Alphanumeric screens with icons: battery status, channel selected, mode selected, audible status and radio frequency lock indicators.

Keyboard

Illuminated soft-touch rubberized keypad. Includes test, zone, up/down, menu and backlight keys. Key lock feature prevents inadvertent setting changes.

Flash Confirmation Cable

The optional "Flash Confirmation Cable" indicates that a triggered remote flash actually fired. By utilizing a shielded high intensity light sensor, which only remains active during the brief radio transmitting time, it confirms only if the attached flash fired or not. Flash confirmation status is sent to the attached receiver and in return sent back to the transmitter.

Specifications

Range: 1600 feet or more
Channels: 32 Digitally coded ID#s
16 Original Classic
16 Quad-Triggering
Sync Speed:
Up to 1/250 (focal plane)
Up to 1/500 (leaf shutter)
Up to 1/100 (Fast Mode)
Power: 2-AA batteries
AC Adapter: Optional # 804105
Weight: 5.4 oz (w/batteries)
Dimensions:
2.1" W x 1.4" D x 4.0" H
Flexible Antenna 2.4"

Pocket Wizard MultiMAX Transceiver (802450)

Item # WIPWMMT **295.00**

Communication Technology Features

- Wireless Transceiver Technology
- True Trigger Confirmation
- Selective Quad-Triggering
- Digital Radio Technology

Trigger Time Controller Features

- Rear Curtain Sync
- Precision Delays
- MultiPop (Multiple Flash Exp.)
- Intervalometer
- Speed Cyler
- Lag Time Equalizer
- Ready Mode

SLAVES

CABLES

CAMERA SYNC CABLES

- | | |
|---|---|
| PC to Miniphone,
1' Straight (804301)
<i>Item # WICPCM1.....17.95</i> | Locking PC to Miniphone,
5' Coiled (804304)
<i>Item # WICPCNLM5.....19.95</i> |
| PC to Miniphone,
5' Coiled (804302)
<i>Item # WICPCM5.....17.95</i> | PC to Miniphone,
10' Straight (804305)
<i>Item # WICPCM10.....21.95</i> |
| Long Tip PC to Miniphone,
5' Coiled (804303)
<i>Item # WIPCLTM5.....29.95</i> | PC to Miniphone,
16' Straight (804306)
<i>Item # WICPCM16.....35.95</i> |

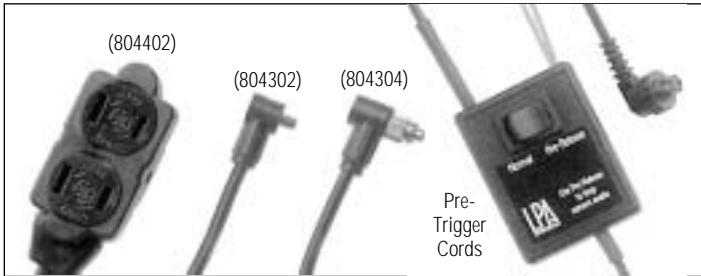

ELECTRONIC FLASH CABLES

- | | |
|---|--|
| Miniphone to Miniphone,
10' Straight (804401)
<i>Item # WICMMM10.....19.95</i> | Submini Male to Miniphone,
16" Straight (804410)
<i>Item # WICSMM16.....17.95</i> |
| Triple Household Female,
16' Straight (804402)
<i>Item # WICHFM16.....24.95</i> | Submini Male to Miniphone,
3' Straight (804411)
<i>Item # WICSMM3.....16.95</i> |
| Household to Miniphone,
16" Straight (804403)
<i>Item # WICHHM16.....17.95</i> | Elinchrom to Miniphone
16" Straight (804412)
<i>Item # WICEM16.....46.95</i> |
| Household to Miniphone
3' Straight (804404)
<i>Item # WICHM3.....17.95</i> | Mini Right Angle Extra Long to
Miniphone, 16" Straight (804413)
<i>Item # WICM16CL.....17.95</i> |
| Household to Miniphone
10' Straight (804405)
<i>Item # WICHM10.....17.95</i> | Metz 6 Pin to Miniphone
16" Straight (804414)
<i>Item # WICM6PM16.....33.95</i> |
| 1/4" Phono to Miniphone
16" Straight (804406)
<i>Item # WIC.25M16.....17.95</i> | Metz 8 Pin to Miniphone
3' Straight (804415)
<i>Item # WICM8PM16.....35.95</i> |
| 1/4" Phono to Miniphone
3' Straight (804407)
<i>Item # WIC.25M3.....17.95</i> | Sunpak to Miniphone
1' Straight (804416)
<i>Item # WICSM1.....17.95</i> |
| Miniphone Right Angle to
Miniphone, 16" Straight (804408)
<i>Item # WICMM16.....17.95</i> | Vivitar to Miniphone
1' Straight (804417)
<i>Item # WICVM1.....17.95</i> |
| Miniphone Right Angle to Miniphone, 6' Straight (804409)
<i>Item # WICMM6.....17.95</i> | |

MOTOR DRIVE CABLES

- | | |
|---|--|
| Canon N3
Motor Drive Cable (804501)
<i>Item # WIMCCE3M3.....112.95</i> | Rollei
Motor Drive Cable (804505)
<i>Item # WIMCRM3.....104.50</i> |
| Canon T3
Motor Drive Cable (804502)
<i>Item # WIMCCE1NM3.....63.50</i> | Mamiya
Motor Drive Cable (804506)
<i>Item # WIMCMRZM3.....94.95</i> |
| Nikon 10 Pin
Motor Drive Cable (804503)
<i>Item # WIMCNN90M3...177.50</i> | Mamiya 645AF
Motor Drive Cable (804507)
<i>Item # WIMCM645AFM3.94.95</i> |
| Nikon
Motor Cord (804504)
<i>Item # WIMCNM3.....68.50</i> | Hasselblad
Motor Drive Cable (804508)
<i>Item # WIMCHM3.....72.95</i> |

PRE-TRIGGER CABLES

- | | |
|---|--|
| Canon N3 Motor Drive
Pre-Trigger (804511)
<i>Item # WIPTCE3.....142.85</i> | Rollei Motor Drive
Pre-Trigger (804515)
<i>Item # WIPTCR6.....124.95</i> |
| Canon T3 Motor Drive
Pre-Trigger (804512)
<i>Item # WIPTCCAFQ.....104.50</i> | Mamiya Motor Drive
Pre-Trigger (804516)
<i>Item # WIPTCMRZ.....134.95</i> |
| Nikon Motor Drive
Pre-Trigger (804513)
<i>Item # WIPTCNF5.....197.95</i> | Mamiya 645AF Motor Drive
Pre-Trigger (804517)
<i>Item # WIPTCM645AF...134.95</i> |
| Nikon 2 Pin Motor Drive
Pre-Trigger (804514)
<i>Item # WIPTCNF3.....96.95</i> | |

Cables

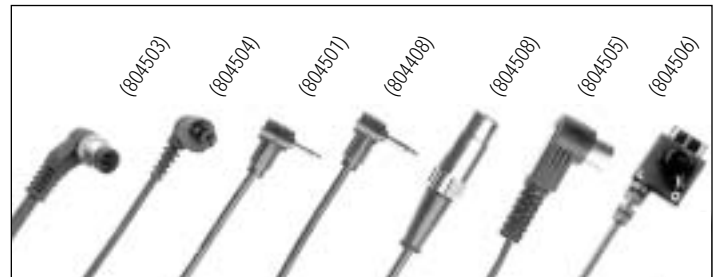

ADAPTERS AND TRIGGER BUTTONS

- | | |
|---|---|
| Household Female
to Mini Adapter (804601)
<i>Item # WIHFMMA.....23.95</i> | Trigger Button to Miniphone
3' Straight (804604)
<i>Item # WITBM3.....29.95</i> |
| Sub-Mini Female
to Mini Adapter (804602)
<i>Item # WISMFMMA.....6.50</i> | PC Female to
Mini Adapter (804605)
<i>Item # WIPCFMA.....14.95</i> |
| Trigger Button to Miniphone
16" Straight (804603)
<i>Item # WITBM16.....29.95</i> | AC Adapter for Original
Pocket-Wizard (804106)
<i>Item # WIACAPW.....46.95</i> |

RADIO SLAVE 4i SYSTEM



System includes wireless flash sync and wireless shutter release, using up-to-date digital circuitry. Provides a coded radio signal that works indoors, outdoors, around corners and through walls. Line of sight is not required between Sender and Remote.

Improvements include:

- An extended range to 350' (110m). With the antenna down, range is up to 200' (60m).
- There is a hot shoe mount for the Sender. This allows the unit to attach to a camera shoe, and sync cord is not required. Or use provided Quantum sync cord to connect to camera sync. Also can be mounted to brackets, dead shoes, etc. with velcro (supplied).
- Has a much longer battery unit for Remote unit. With 4 "AA" alkaline batteries you receive up to 400 hours (up from 80 for previously used (2) 9V batteries). Up to 800 hours with 4 "AA" Lithium batteries. The Remote can also use AC power with accessory models.
- Faster sync speed. 1/500 sec. (focal plane) & 1/1000 sec. (leaf shutter) for cameras with extremely fast shutter sync. Extremely fast synchronization means Radio Slave 4i is virtually indistinguishable from "wired sync".

Radio Slave 4i maintains these features:

- Trigger any number of remote flashes without a sync cord. Or you can trip a motor drive camera with accessory cords, or a remote power pack at great distances. Unlike other types of slaves, the Radio Slave 4i cannot be overpowered by the light of a flash.
- Status lights on both Sender and Remote confirm proper operation and/or low batteries.
- Superior interference free reception. User selected coded channels permit many Radio Slaves to operate in the same area.
- Radio Slave 4i is compatible with the Radio Slave 4 and Radio Slave 2. Be sure to match the labeled frequency (either A, B, C, D) with your previous units.

Radio Slave 4i Set (505SRI)

Available in A, B, C and D frequencies. Includes: 505Si Sender and 505Ri Remote, belt clip, sync cord, mounting kit, instruction manual, (less batteries). Specify frequency.

Item # QURS4IS() **284.95**

Radio Slave 4i Remote (505RI)

Available in A, B, C and D frequencies. Includes: shoe/tripod mount adapter, pole mount adapter, instruction manual, (less battery).

Specify frequency.

Item # QURS4IR() **190.00**

Radio Slave 4i Sender (505SI)

Available in A, B, C and D frequencies. Includes: sync cord, belt clip, dead shoe with screw (for bracket mounting), velcro, and mounting plate.

Specify frequency.

Item # QURS4IS() Q **139.95**

Specify frequency A, B, C or D in parenthesis.

FREEWIRE DIGITAL TRANCEIVER

Features

- Next generation wireless flash sync and camera trigger.
- FreeWire transceivers can be set as a Sender or Remote unit, or both.
- Wireless TTL control for Qflash.
- 8 non-interfering system settings.
- 4-Zones (channels). Set any Zone or combination on or off.
- Confirmation signal echoed back to the Sender and displayed.
- Relay signals with FreeWire for unlimited range.

FreeWire

Digital Transceiver (FW10)

Item # QUFW10.....**205.95**

FreeWire is truly a new generation of wireless transceiver photo control. Each FreeWire unit is capable of transmitting and receiving trigger signals. A studio owning FreeWire devices can set them as needed. For example, 4 units can become 2 sets of Senders and Remotes, or one Sender and 3 Remotes, as assignments change. After a FreeWire Remote unit receives a signal it sends back a confirmation to the Sender. Set up and check out are greatly simplified! When used with Quantum's TTL adapters (available for all popular cameras) FreeWire provides wireless TTL control of remote Qflash T's and X's.

To avoid interfering with other photographers, you can set FreeWires to any of 8 System settings. FreeWires operating on different Systems will not interfere. With each System setting you can also control 4 Zones or channels. Select any Zone or any combination of Zones to activate flash and cameras in groups or individually, right from the FreeWire Sender. A great time saver in changing situations!

The FreeWire transceiver receives and resends trigger signals. This feature lets you easily synchronize remote camera / remote flash set ups, or relay trigger signals to distant FreeWires.

FreeWire is conveniently compact and mounts easily to brackets, or to hot shoes using the optional Unimod attachment. A swiveling antenna stores away from damage.

Of course, FreeWire generates digital signals coded and checked for accuracy, eliminating interference and assuring reliability. FreeWire's advanced design will complement new developments to come from Quantum.

FreeWire is the remote photo control you've been waiting for.



ACCESSORIES



- Dead Shoe Mounting Kit (512)
for 505 Si (Replacement).
Item # QUMKDS505SI.....8.95
- AC Adapter for 505Ri (515)
Item # QUACA505RI.....26.50
- 115V AC Adapter/Charger (415)
for 405/505R.
Item # QUACACRS4R.....29.95
- AC Adapter (220V) f/505Ri (516)
Item # QUACA505RIX.....23.95
- Belt Clip for 405T (438)
Item # QUBCRS2T.....9.95
- Belt Clip (538)
for 505Si Sender (replacement).
Item # QUBC505SI.....5.95
- Belt Clip for 505S (511)
Item # QUBCRS4T.....9.50

SYNC CORDS

- 1' (0.3m) Sync Cord (434)
for 405T.
Item # QUSC1RS2T.....26.50
- 4' (1.2m) Coiled Sync Cord (435)
for 405T.
Item # QUSC4RS2T.....26.50
- Sync Cord (470)
for Hasselblad "C" Lens.
Item # QUSCHRS2T.....29.95
- Sync Cord (570)
for Hasselblad "C" Lens.
Item # QUSCHCRS4T.....29.95
- 18" (46cm) Coiled Sync Cord
with Center Pin (536)
for 505S.
Item # QUSCCP18RS4T ... 26.50
- 18" (46cm) Coiled Sync Cord (534)
for 505S.
Item # QUSC18RS4T.....26.50
- 5' (1.5m) Coiled Sync Cord (535)
for 505S.
Item # QUSC5RS4T.....25.95
- 5' Coiled Sync Cord
with Center Pin (537)
for 505S.
Item # QUSCCP5RS4T.....24.95
- 12" (30cm) Straight Sync Cord (539)
for 505S/Si.
Item # QUSCS12RS4T.....26.50

MD CORDS

- MD Cord (451)
for Nikon.
Item # QUMDC451.....47.95
- MD Cord (452)
for Hasselblad ELM/ELX.
Item # QUMDC452.....49.50
- MD Cord (453)
for Canon/Olympus/Bronica.
Item # QUMDC453.....44.95
- MD Cord (454)
for Mamiya RZ/645 Super.
Item # QUMDC454.....76.50
- MD Cord (455)
for Minolta (except 7000/9000).
Item # QUMDC455.....79.95
- MD Cord (456)
for Leica.
Item # QUMDC456.....74.95
- MD Cord (458)
for Minolta 7000/9000.
Item # QUMDC458.....82.95
- MD Cord (459)
for Canon T90/620 EOS/EOS1.
Item # QUMDC459.....74.95
- MD Cord (461)
for Pentax ME 11 Super.
Item # QUMDC461.....68.95
- MD Cord (463)
for Bronica SQAI.
Item # QUMDC463.....56.95
- MD Cord (464)
for Rollei 6008/6006/6002.
Item # QUMDC464.....56.95
- MD Cord (465)
for Hasselblad 503-CW/CXI.
Item # QUMDC465.....39.95
- MD Cord (466)
for Canon EOS 3, IV, D30.
Item # QUMDC466.....89.50
- MD Cord (467)
for Mamiya 645AF.
Item # QUMDC467.....62.50

MD Cords

ACCESSORIES FOR FREEWIRE

- Universal Connector Module
with Hot Shoe (FW11)
Item # QUFW11.....49.50
- 18" Sync-In Cord (FW20)
Item # QUFW20.....29.95
- 18" Hot Shoe Sync Cord (FW21)
Item # QUFW21.....39.95
- 18" Ext. Cable to
Qflash/Unimod (FW31)
Item # QUFW31.....29.95
- Two Step MD Cord (FW41)
For Contax 645.
Item # QUFW41.....33.95
- Two Step MD Cord (FW42)
For Maxxum 7/9.
Item # QUFW42.....89.50
- Wireless TTL Adapter (FW52)
for Nikon.
Item # QUFW52.....76.95
- Wireless TTL Adapter (FW53N)
for Canon.
Item # QUFW53N.....86.95
- External Power
Connection (XDC2)
from Bantam or QB1c to
FreeWire.
Item # QUXDC2.....29.95

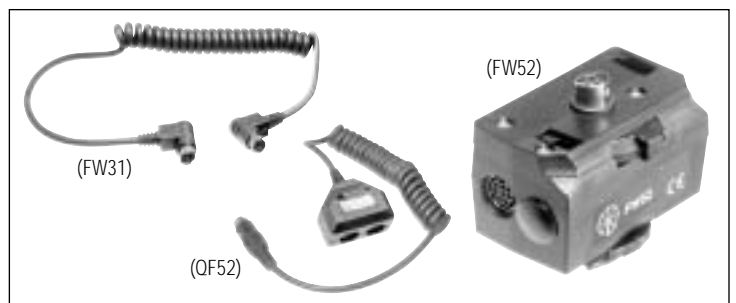

- External Power
Connection (MDC2)
from QB1c, or QB1 to
FreeWire.
Item # QUMDC2.....26.50
- Y Connector for
FreeWire TX (OF52)
To connect a TTL adapter plus a
local Qflash and FW31 cable.
Item # QUQF52.....44.95

BATTERY-FREE PHOTO SLAVES

Wein started writing the book on photocells over 25 years ago, and today offers the widest range of professional flash slaves available. Whether you want to trigger a shoe flash from across the room, or a gaggle of 4800 w/s packs from an arena catwalk, Wein has a slave that will do the job. All are solid, tough and reliable, and there's a model available for any type of flash connection. And leave the batteries in the bag; Wein slaves don't use any.

ULTRA SLAVES (SSL/XL)

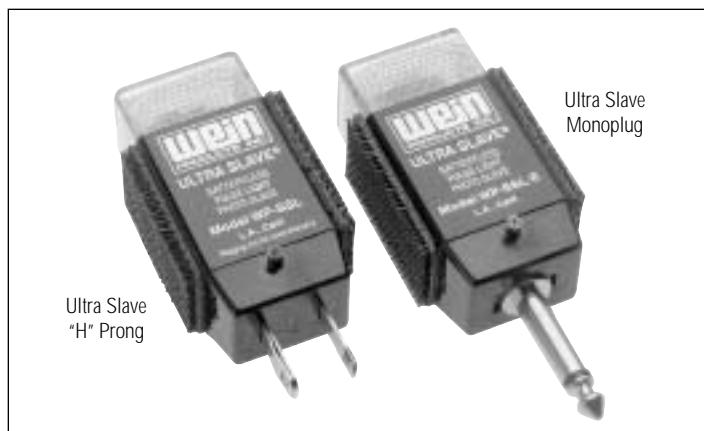

- The most sensitive photo slave available; range up to 3000' (914m)!
- Works indoors or out: ambient light filter prevents interference from bright sunlight or false-triggering from flickering fluorescents.
- Available with either "H"-prong or monoplug sync connector for direct connection to virtually any professional flash or power pack.
- All Ultra slaves feature standard PC terminal as alternative sync connector.
- Lower-sensitivity XL Model (range up to 600' 183m) is also available.

SSL Ultra Slave
3000' (914m) (930010)
"H"-prong.
Item # WESSL **89.95**

SSL-E Ultra Slave
3000' (914m) (930015)
Monoplug connector.
Item # WESSLE **99.95**

XL Ultra Slave
600' (183m) (930020)
"H" prong.
Item # WEXL **74.95**

XL-E Ultra Slave
600' (183m) (930025)
Monoplug connector.
Item # WEXLE **84.95**

HIGH-PERFORMANCE "PEANUT" (PN-XL)

- Enhanced version of the original "Peanut" slave
- Range up to 300' (91m)
- Ambient light-filtered for outdoor use.
- Standard PC sync connector

High Performance "Peanut"
(PN-XL) (940020)
Item # WEPNXL **34.95**

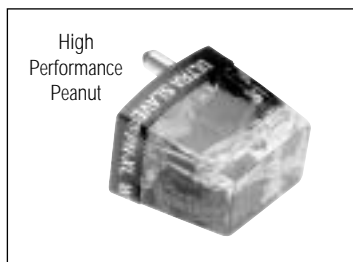

HOT SHOE SLAVES (HS)

- Attach directly to foot of any shoe-mount flash – no other connection necessary.
- Range up to 150' (46m) (HS model) or 600' (183m) (HS-XL).
- HS-XL features built-in ambient light filter for outdoor use.
- Constructed of aircraft aluminum and solid epoxy; virtually indestructible.
- Integral 1/4"-20 threaded socket for tripod, monopod or light stand mounting.
- PC terminal for use with non-shoe flash units.

HS Hot Shoe Slave
150' (46m) (940030)
Item # WEHS **34.95**

HS-XL Hot Shoe Ultra Slave
600' (183m) (940040)
Item # WEHSXL **79.95**

THE "PEANUT" (PN)

- Tiny size, weighs less than 1/2 ounce!
- Up to 100' (30m) range (indoors).
- Solid cast epoxy won't crack, protects micro-circuitry inside.
- Standard PC sync connector plugs directly into Vivitar 283/285. Connects to any other flash via PC cord.
- Available individually or in economical 3-pack.

The "Peanut" (PN) (940001)
Item # WEPN **19.95**

Peanut Slave (PN3)
(3-Pk.) (940003)
Item # WEPN3 **54.95**

MICRO SLAVE (L8)

- The original battery-free photo slave.
- Range up to 150' (46m).
- Super-compact; smaller than a 35mm film cartridge.
- "H"-prong connector

Micro Slave (L8) (940050)
Item # WEL8 **29.95**

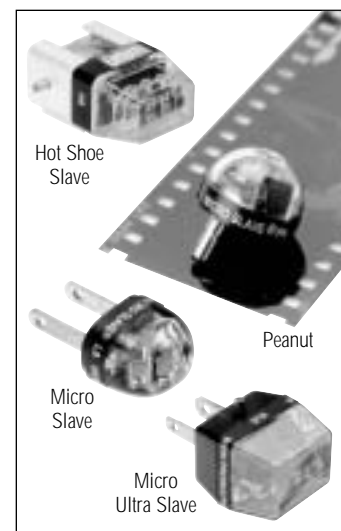

MICRO ULTRA SLAVES (XL8)

- High-performance version of the original Micro Slave.
- Range up to 400' (122m).
- Ambient light-filtered for reliable outdoor use.
- Available with either "H"-prong or monoplug connector; both have standard PC terminal as alternate sync connection.

XL8 Micro Ultra Slave (940060)
"H" Prong.
Item # WEXL8 **44.95**

XL8-E Micro Ultra Slave (940070)
Monoplug connector.
Item # WEXL8E **59.95**

PRO-SYNC CODED INFRARED SYSTEMS

If you shoot weddings, events, industrial or other location work, Pro-Sync is for you. Pro-Sync provides cordless, omni-directional remote flash control with virtual immunity to interference. Unlike radio frequency (RF) remote flash control systems, Pro-Sync uses state-of-the-art coded infrared technology to fire remote flash units. Common sources of radio interference, like cellular phones, pagers, and cordless microphones (increasingly common at weddings), can disrupt radio flash signals, but are no threat to Pro-Sync. Because the Pro-Sync signal is encoded, the system cannot be triggered by any flash or light source.



LIGHTING TIP

Using large reflectors in bright outdoor sunlight can be a lifesaver. You can either shield the bright sunlight or reflect it into the shadow areas to keep the subject contrast ratio within the sensitivity range of the film.

The Transmitter

The Pro-Sync transmitter can be mounted on, and fired by, any standard camera hot shoe (or connected to a PC terminal for off shoe use). Just slide the compact transmitter onto your camera and forget it; no cords, no antenna, nothing to clip to your belt. A pair of "AA" batteries in the transmitter provides power for up to 5,000 shots, with recycle times averaging less than a second; that's faster than almost any flash, so your Pro-Sync is up and ready when you are. Each time you shoot, the transmitter fires, and an "explosion" of coded infrared lights fills the room, bouncing off walls and around corners. You can't see the signal (neither can your film), but the Pro-Sync receiver sure can.



PRO-SYNC 1

An economical, basic infrared remote control system with great performance.

- Features a single, private-protected transmit/receive channel.
- Allows for use of on-camera flash with use of optical Sync-Link accessory.

PS-500-1 Pro-Sync 1 Channel System (W910100) "H" prong.
Item # WEPS5001209.95

PS-500-1E Pro-Sync 1 Channel System (W910150) Monoplug connector.
Item # WEPS5001E234.95

The Receiver

Plugged into your remote flash, the Pro-Sync receiver is in a "standby" mode, waiting for the transmitter signal. Nothing else can trigger the receiver, not even a full-power flash fired inches away. Pro-Sync receivers are incredibly sensitive and can easily pick up the signal from behind backdrops, soft boxes, even around a roomful of wedding guests. They work indoors or out, with a maximum range of 600 feet (183m) (indoors). The Pro-Sync receiver draws its power from the flash to which it is connected, so there are no batteries to change. Receivers are available with either integral "H" prong or monoplug sync connectors, so they connect directly, cordlessly, to most professional flash units or power packs. For additional versatility, each receiver also has a standard PC terminal.

PRO-SYNC 1

SYNC-LINK

Lets you use a Pro-Sync transmitter without giving up TTL flash! The Sync-Link frees the camera hot shoe for connecting a TTL flash unit or off camera cord. It attaches with Velcro to the TTL flash, senses when it fires, then completes the circuit that fires the Pro-Sync transmitter. Sync-Link keeps the transmitter out of the loop, allowing for normal connection of the dedicated flash to the camera. May also be used to add on-camera/remote flash switching capability, similar to that of the Pro-Sync LX, to the Pro-Sync 1 system.

Sync-Link (W990600)
Item # WESLMP46.95

DIGITAL SMART SLAVES

Wein's Digital Smart Slaves are solid-state, batteryless slaves that can perfectly synchronize with digital preflash cameras. Just plug them in and you have fabulous, optically slaved remote lighting enhancement for the weak, built-in digital camera flash. These miniature batteryless encapsulated digital slaves can be attached to your existing flash units by sync cord, hot shoe, pc, monoplug or H prong and will perfectly synchronize the flash with your digital camera by optical wireless remote control. Make any digital camera into a wireless remote lighting enhancement transmitter for truly professional results.

Peanut Slave Digital (W940001D) (Peanut Slave): PC only, 100' range.
Item # WEPND34.95

High Performance Peanut Digital (W940020D) PC only (full sunlight protection) 300' range.
Item # WEPNXL69.95

Hot Shoe Slave Digital (W940030D) PC and Hot Shoe, 150' range.
Item # WEHSD69.95

Hot Shoe Ultra Slave Digital (W940040D) PC and Hot Shoe (full sunlight protection) 600' range.
Item # WEHSXL109.95

Micro Ultra Slave (W940060) PC and H prong power pak input (full sunlight protection) 400' range.
Item # WEXL844.95

Micro Ultra Slave Digital (W940070D) PC & Monoplug power pak input (full sunlight protection) 400' range.
Item # WEXL8ED89.95

SSL Ultra Slave Digital (W930010D) PC and H prong (full sunlight protection) 3000' range.
Item # WESSLD109.95

SSL Ultra Slave Digital (W930015D) PC and Monoplug (full sunlight protection) 3000' range.
Item # WESSLED109.95

SLAVES / ACCESSORIES

SLAVES

HIGH-POWERED SLAVE/TRIGGER KITS

SSR systems let you fire your slaved strobes without triggering flash. No need to hook up a PC cord to the main flash or use a camera-mounted strobe; the SSR transmitter replaces them both. Mount the compact transmitter on your hot shoe, or connect it to the camera PC terminal; each time you shoot, the SSR transmitter fills the studio with an invisible pulse of light. A super-sensitive SSL Ultra Slave picks up the signal from any direction and fires the main flash, which in turn triggers all other slaved strobes in the setup. Simple, reliable, professional.

SSR

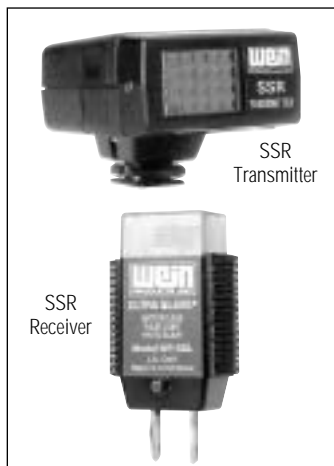

- High-powered, for big studios or large-scale industrial/architectural work
- Maximum range 600 feet (183m)
- Two "AA" batteries in the transmitter power up to 5,000 shots. With fresh batteries, transmitter recycle times average less than 1 second, so you'll never miss a shot.

SSR Transmitter and Ultra Slave Receiver (920200)
"H" prong.
Item # WESSR.....189.95

SSR Transmitter and Ultra Slave Receiver (920250)
Same as above with Monoplug connector.
Item # WESSRE.....204.95

METER MATE 2

Triggers your flash for meter readings...cordlessly! Meter-Mate 2 is an ultra-compact slave trigger that eliminates the need for a PC hookup to your flash meter when taking exposure readings. Just Velcro to your flashmeter and plug into the PC terminal, then connect a Wein SSL Ultra Slave (at least one required) to the main flash. Each time you press the flashmeter exposure button, Meter-Mate 2 emits an invisible pulse of infrared light that fires your entire slaved flash setup, cordlessly, from up to 100' (30m) away. Transmitter comes with a replaceable battery that powers up to 5000 firings. An ideal addition to SSR studio remote systems.

Meter-Mate 2 Slave Trigger (990750)
Item # WEMM2.....57.95

Meter-Mate 2 Slave Trigger (920500) with SSL Receiver.
Item # WEMM2K.....139.95



ACCESSORIES

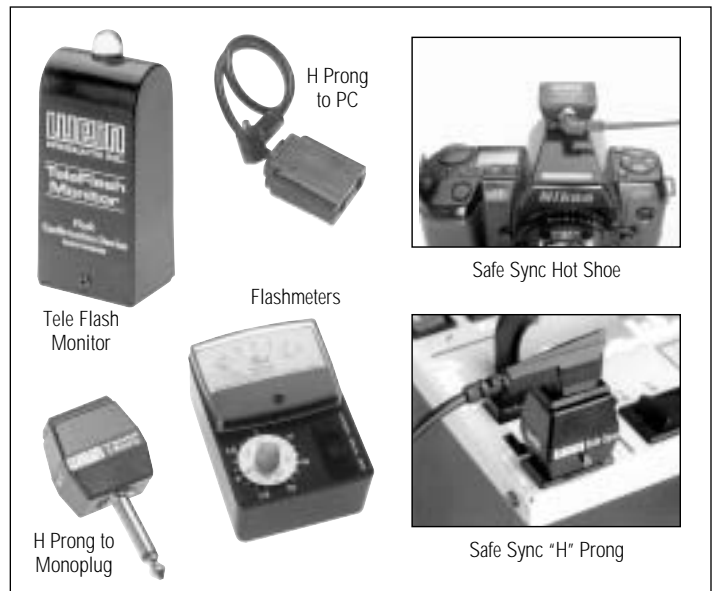

TeleFlash Monitor (W970100)
Positively lets you know that every remote flash fired, every time. Stick a cordless TeleFlash onto each flash in your setup (or clip it to the flash cord for better visibility). TeleFlash detects the electro-magnetic surge of a good flash firing, blinks a bright red LED for 5-10 seconds, then automatically resets for the next shot. A quick glance at each TeleFlash in your studio gives you instant, reliable flash confirmation. A single 9V battery (not included) provides power for thousands of activations.
Item # WETFM100.....49.95

Flashmeters
■ Economical, reliable, excellent for serious enthusiasts.
■ Trouble-free analog operation.
■ Standard model provides readings for f2-f22, accurate to 1/3 stop.
■ Deluxe model provides readings from f2-f90, accurate to 1/6 stop.

Standard Flashmeter (950010)
Item # WEWP500B.....89.95

Deluxe Flashmeter (950020)
Item # WEWP1000.....129.95

Safe-Sync
Regulates flash sync voltage to 6 volts – protects your camera's circuitry! Over time, excessive flash synchronization voltage can lead to damage and costly repair; Safe-Sync offers a simple and effective way to protect your camera. No matter how high the original voltage, Safe-Sync reduces it to a safe 6 volts. Available in a hot shoe version with a threaded PC terminal, or in a "H"-prong model for use with studio power packs.

Safe-Sync SSH ("H" Prong) (990500)
Item # WESSQ.....54.95

Safe-Sync HS (Hot Shoe) (W990560)
Item # WESSHSH.....49.95

ADAPTERS

"H"-Prong to Monoplug Adapter (990315)
Item # WEPHH.....19.95

"H"-Prong to PC Adapter, 9" Cord (990305)
Item # WEPCHA.....19.95

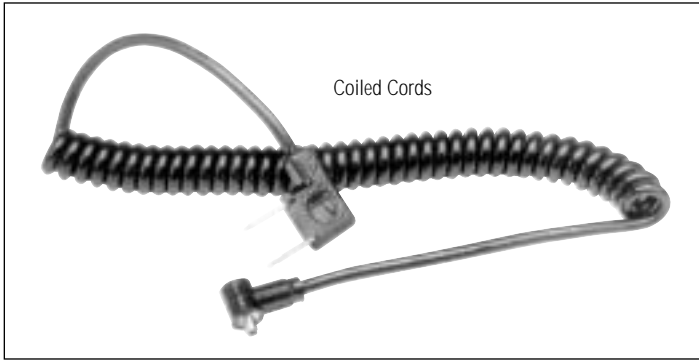

6-IN. TO 1-FT. STRAIGHT CORDS

Item	#	SKU	Cat. #	Price
Household to PC 6"	H-PC-6	PAHHPCF6	PMHPC6	12.95
Vivitar to Household Female 6"	V-SL	PAVHHF6	PMVSL	12.95
Household Female to PC Female 6"	HF-PF	PAHHFPCF6	PMHFPF	13.95
Household Female to Household Male 6"	HH-HHF	PAHHFHHM6	PMHHHF	12.95
Elinchrom to Household Female 6"	EC-HF	PAEHHF6	PMECHF	39.95
Household Male to Household Female 6"	HH-HF	PAHHMHF6	PMHHHF	12.95
Household to PC - Long Tip 1'	A2-1S	PAHHPCL1	PMA21S	12.59
Household to Nikon Screw Lock 1'	5-1S	PAHHNSL1	PM51S	12.59
Household to Manual Tripper 1'	T-1S	PAHHT1	PMT1S	18.50
Sunpak to PC 1'	SP-1S	PASPC1	PMSP1S	12.59
Vivitar to PC 1'	V-1S	PAVPC1	PMV1S	12.59
Household to Bi-Post 1'	1-19	PAHHBP1	PM11S	12.59
Household to PC 1'	2-1S	PAHHPC1	PM21S	12.59

3-FT. COILED CORDS

Cord	#	Item #	Cat. #	Price
Household to PC	2-3C	PAHHPC3	PM23C	16.50
Household to PC - Long Tip	A2-3C	PAHHPCL3	PMA23C	16.95
Quantum Radio II to PC - Long Tip	Q3C	PAQRPC3	PMQ3C	17.95
Sunpak to PC	SP-3C	PASPC3	PMS3C	16.95
Vivitar to PC	V-3C	PAVPC3	PMV3C	16.95

18-IN. STRAIGHT CORDS

Item	#	SKU	Cat. #	Price
Household to PC 18"	2-18	PAHHPC18	PM218	14.95
Household to PC - Long Tip 18"	A2-18	PAHHPCL18	PMA218	14.95

5-FT. COILED CORDS

Item	#	SKU	Cat. #	Price
Household to Bi-Post	1-6C	PAHHBP5	PM16C	17.19
Household to PC	2-6C	PAHHPC5	PM26C	17.19
Household to PC - Long Tip	A2-6C	PAHHPCL5	PMA26C	17.19
Household to Rollei Lock	3-6C	PAHHR5	PM36C	17.19
Household to Nikon Push Lock	4-6C	PAHHNPL5	PM46C	17.19
Household to Nikon Screw Lock	5-6C	PAHHNSL5	PM56C	17.19
PC Male to PC Female	8-6C	PAPCMPCF5	PM86C	17.19
PC Male to PC Male	B-6C	PAPCMPCM5	PMB6C	17.19
Vivitar to PC	V-4C	PAVPC5	PMV4C	17.19
Sunpak to PC	SP	PASPC5	PMS5	17.19
PC to PC (Metz Long PC)	M-4C	PAPCMPCM5	PMM4C	17.19
Hasselblad C Lens to Household	S-4C	PAHHHC5Q	PMS4C	19.50
Household to Koni-Omega Screw Lock	K-6C	PAHHKO5	PMK6C	17.19
Vivitar to Nikon Screw Lock	V5-4C	PAVNSL5	PMV54C	17.19
Honeywell Lock to PC	2H-6C	PA2H6C	PM2H6C	17.19
Rollei Lock to PC	23-6C	PARLPC5	PM236C	17.19

10 TO 15-FT. STRAIGHT CORDS

Item	#	SKU	Cat. #	Price
Household to PC 10'	2-10S	PAHHPC10	PM210S	17.95
Monolite to PC 10'	ML	PAMLPC10	PMML	21.95
Household Male to Household Female 10'	HH-10S	PAHHMHF10	PMH10S	16.50
Elinchrom to PC 15'	ECA-15S	PAEPC15	PMECA15S	39.95
Household to PC 15'	2-15S	PAHHPC15	PM215S	19.99
PC Male to PC Female 15'	8-15S	PAPCMPCF15	PM815S	19.99
Monolite to Household Female 15'	HPC-S	PAMLHHF15	PMMLHFHD	26.50
Broncolor to PC 15'	SB-15S	PASPC15	PMSB15S	26.95

16-FT. COILED CORDS

Item	#	SKU	Cat. #	Price
Household to PC	2-16C	PAHHPC16	PM216C	24.95
Household to PC - Long Tip	A2-16C	PAHHPCL16	PMA216C	24.95
PC Male to PC Female	8-16C	PAPCMPCF16	PM816C	24.95
Vivitar to PC	V-16C	PAVPC16	PMV16C	24.95



SYNC CORDS

METZ CORDS

Item	#	SKU	Cat. #	Price
60CT4 to PC 3' Coil	CL3C	PAMPC3	PMCL3C	24.29
60CT4 to PC 18' Straight	CL18	PAMPC18	PMCL18	24.29
60CT4 to 5' Coil	CL6C	PAMPC5	PMCL6C	24.29
60CT4 to PC Long 5' Coil	CLA-6C	PAMPCL5	PMCLA6C	24.29
60CT4 to PC 15' Straight	CL15S	PAMPC15	PMCL15S	24.29
60 CT4 to PC 1' Straight	CL41S	PAMPC1	PMCL41S	19.95
45CT1 to PC 15' Straight	ZSQ-15S	PAMPC15Z	PMZSQ15S	29.50
45CT1 to PC 18' Straight	ZSQ-18	PAMPC18Z	PMZSQ18	24.95
45CT1 to PC 1' Straight	ZSQ-1S	PAMPC1Z	PMZSQ1S	22.95
45CT1 to PC 3' Coil	ZSQ-3C	PAMPC3Z	PMZSQ3C	28.50
45CT1 to PC 5' Coil	ZSQ-6C	PAMPC5Z	PMZSQ6C	29.50
45CT1 to PC Long Tip 5' Coil	ZSOA-6C	PAMPCL5Z	PMZSOA6C	29.95
60CT1/2 45 CT5 to PC 15' Straight	Z815S	PAMPC150	PMZ815S	29.50
60CT1/2 45CT5 to PC 18' Straight	Z818	PAMPC180	PMZ818	24.95
60CT1/2 45CT5 to PC 1' Straight	Z81S	PAMPC10	PMZ81S	22.95
60CT1/2 45CT5 to PC 3' Coil	Z83C	PAMPC30	PMZ83C	28.50
60CT1/2 45CT5 to PC 5' Coil	Z86C	PAMPC50	PMZ86C	28.50
60CT1/2 45CT5 to PC Long Tip	Z8A6C	PAMPCL50	PMZ8A6C	29.95

GOLD TIP CORDS

Item	#	SKU	Cat. #	Price
Household to PC Long 5' Coil	G2-6C	PAHHPC15G	PMG26C	26.95
Household to PC Long 3' Coil	G2-3C	PAHHPC13G	PMG23C	25.95
Household to PC Long 1' Straight	G2-1S	PAHHPC11G	PMG21S	19.95
Household to PC Long 15' Straight	G2-15S	PAHHPC15G	PMG215S	27.50
Household to PC Long 18' Straight	G2-18	PAHHPC18G	PMG218	24.95

HV TURBO CORDS

Item	SKU	Cat. #	Price
Vivitar to Lumedyne 5' Coil	PAHVCV	PMCV	29.95
Sunpak 544/545/611 to Lumedyne	PAHVCS	PMCS5	29.95
45CL3/4/5 to Lumedyne 5' Coil	PAHVCM	PMCM4	29.95
Nikon SB24 to Lumedyne 5' Coil	PAHVCN	PMCK	31.95
Canon 430/450 EZ to Lumedyne 5' Coil	PAHVCC	PM CZ	29.95
45CT1/5 to Lumedyne 5'	PAHVCMQ	PMCM1	29.95
Sunpak 422/433/444 to Lumedyne 5'	PAHVCSQ	PMCS4	29.95
Metz 50 to Lumedyne 5' Coil	PAHVCM50	PMCL5	29.95
Turby Turbo Splitter Y Cord	PATS	PMTURBOY	29.95

PC CONDITIONERS

Item	#	SKU	Cat. #	Price
PC Tip Conditioner	PCC	PATCPC	PMPCC	9.95
Deluxe PC Tip Conditioner	PCD	PATCDPC	PMPCD	14.95

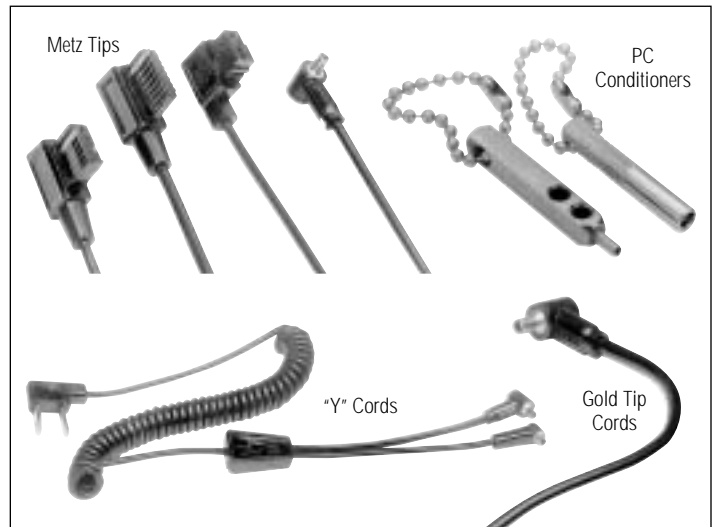

HOT SHOE CORDS

Item	#	SKU	Cat. #	Price
Household to Hot Shoe 5' Coil	HS-6C	PAHHHS5	PMHS6C	19.50
Household to Hot Shoe 3' Coil	HS-3C	PAHHHS3	PMHS3C	19.50
Vivitar to Hot Shoe 5' Coil	VHS-6C	PAVHS5	PMVHS6C	19.50
Sunpak to Hot Shoe 5' Coil	SHS-6C	PASHS5	PMSHS6C	19.50
Household to Hot Shoe 1' Straight	HS-1S	PAHHHS1	PMHS1S	14.95
Household to Hot Shoe 15' Straight	HS-15S	PAHHHS15	PMHS15S	22.50

LOW VOLTAGE CORDS

Item	#	SKU	Cat. #	Price
Canon EZ to QB1 Low Volt	LV-EZ	PALVCC	PMLVEZ	39.95
Nikon to QB1 Low Volt	LV-NIK	PALVCN	PMLVNIK	39.50
Sunpak 6 Volt to QB1 Low Volt	LV-SP	PALVCS	PMLVSP	39.50
Vivitar 283/285 to QB1 Low Volt	LV-VIV	PALVCV	PMLVVIV	46.95
Household to PC Long 5' Volt Protected		PAVPHHPC15	PMVPG26C	58.95

MISCELLANEOUS CORDS

Item	#	SKU	Cat. #	Price
Quantum Radio to PC Long	Q-RS	PAQRPC15	PMQRS	13.95
Turb/Cyc to Dynalite Uni400		PAU400T	PMUNITURBO	43.50
Y Cord Household to Hasselblad C/Cf		PAYCH	PMYHASSCCF	39.95

ACCESSORIES

Item	#	SKU	Cat. #	Price
Universal Foot for Vivitar 283/285	283UF	PAUFV	PM283UF	33.50
Optional Hot Shoe f283UF	283OHS	PAHSV	PM283OHS	16.50
Plastic Accessory Shoe	ASH	PAAC	PMASH	9.95
PC Female Mountable Connector	PCF-MOUN	PAPCCF	PMPCFMOUNT	9.95
Monolite Household Female Adapter	MLHF-S	PAMLLHFA	PMMLHFS	14.95
200B 1/4-20		PAFNB200	PM200B	11.95